

Design and Fabrication of 3-Dimensional Lifting Machine

Ranjit Chaudhari¹, Nikhil Pachghare², Bhushan Makde³, Akash Nimje⁴, Shashank V. Gulhane⁵

^{1,2,3,4} Students ⁵Assistant Professor Mechanical Engineering
Gowindrao Wanjari College of Engineering & technology, Nagpur, Maharashtra

shashank.gulhane17@gmail.com

Received on: 05May ,2022

Revised on: 1 June ,2022,

Published on: 3 June,2022

Abstract- As per technical evolution and latest requirement and related trends taken into consideration here effectively created an advanced optimistic system which can be use as a lift with multiple movement and also work as a storage and retrieval system. This system works on rack and pinion technology with vertical movement, horizontal movement and to and fro movement. This complete system is power optimized and work on 2 v DC only with desired current rating according to motor used. This system uses rack and pinion mechanism for horizontal movement and to and fro movement. This system also used rope pulley mechanism for vertical movement. This complete system uses high torque and medium torque motor. This system having advantages i.e. Multilevel movement is possible using advance arrangement, Optimistic design with secured movement, Shock Resistant, Easy to setup anywhere according to design System able to lift any material, human being , machines and devices with the use of high toque motor and proper arrangement of system, This system can be work as a universal lifting system for system for any industry , factories, schools and colleges , hospitals and malls. This system can be applicable to 3-D movement of Lift,3 D movement of crane for material Loading and unloading of materials i.e. concrete,bricks at buildings and towers, 3 D movement of automated multilevel car parking system, Distribution of Books in library racks with multi layer movement, Multi Layer 3 D Movement with painting of walls, Multi Layer 3 D Movement plaster mechanism, Multilayer watering system with 3 D movement, Multilayer land Crushing system with 3 D movement, Multilayer crop cutting system with 3 D movement, Multi level concrete or tar road manufacturing mechanism.

Keywords: D (Dimensional),V(Volts), A (Ampere), W (Watts).

I –INTRODUCTION

As per technical evolution and latest trends taken into consideration , here effectively created an advanced innovative system i.e. storage and retrieval system for 3 dimensional movement which will useful for 3 D movement of lift, 3 D movement of crane for material unloading at buildings and towers, 3 D movement of automated multilevel car parking system. This project uses 2 parallel rack and 4 pinions for horizontal movement. This 4 pinion device moving over 2 long racks. The control movement followed by switch board. In this horizontal rack and pinion movement uses high torque motor For 2 and fro motion also uses rack and pinion. This to and fro motion is use to place a particular object on the floor. For this to and fro motion, here used mini rack and pinion assembly followed by motor. The first major rack and pinion assembly with lifting mechanism use to lift all above assembly. This lifting mechanism uses pully , thick metal thread and high torque motor with 30 RPM rotation. In this project all above mechanism control by switch board. This project can be useful in 3 D movement of lift, 3 D movement of crane for material unloading at buildings and towers,3 D movement of automated multilevel car parking system. This project can be useful in Multistoried building, long

and heighted shopping malls, Schools and colleges, hospitals.

II -METHODOLOGY

This system works on Rack and pinion and ropes any pulley mechanism. There are 3 systems working in this project,

1. Up Lift mechanism of Lift.
2. To and fro movement of Lift
3. Left and right movement of lift

For lifting mechanism here used methodology of, Rope and pulley mechanism which uses lathe passed shaft, 2 lathe passed pulleys which is locked on shaft, metal rope fixed on pulleys with proper alignment and this system is driven by high torque DC motor. This complete lift move up and down and which is guided and supported by lathe passed shaft and casing. As soon as motor starts rotates then according shaft and pulley starts rotate clockwise and anticlockwise depending on our required up down movement.

For Left and right movement of lift , here used methodology of rack and pinion arrangement. Rack and pinion arrangement uses 1 long stationary rack and 2 rotating pinion which are thread coupled with geared rack and driven by dc motor and complete system guided by shaft so as to produce strength. As soon as motor starts rotate then pinions starts to rotate and accordingly system starts moving.

For To and Fro movement of lift, here used methodology of rack and pinion arrangement. Rack and pinion arrangement uses 1 long moving rack and 2 rotating pinion which are thread coupled with geared rack and driven by dc motor and complete system guided by fixed platform

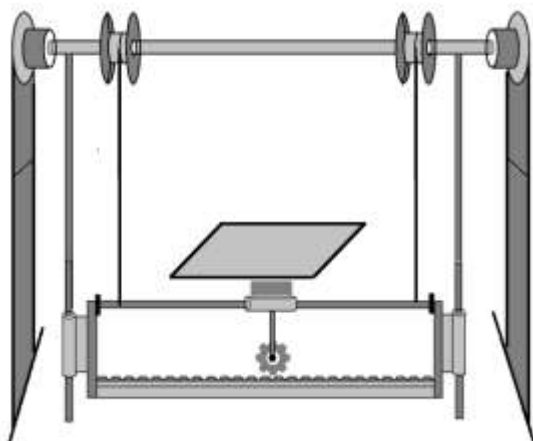

III -DESIGN

1. For To-Fro Motion

$$\begin{aligned}
 W &= 2 \text{ kg} = 19.61 \text{ N} \\
 I &= 1/12 \times b \times d^3 = 254 \text{ mm}^4 \\
 M &= -19.61 \times 381 = 7471.4 \text{ N-mm} \\
 \sigma_{\max} &= (M \times Y_{\max}) / I = 294.14
 \end{aligned}$$

2. For Horizontal Motion

$$\begin{aligned}
 W &= 34.32 \text{ N} \\
 R_a + R_b &= 34.32 \\
 \sum M_a &= 0 \\
 R_a &= 17.16 & R_b &= 17.16 \\
 I &= 7853.9 & Y_{\max} &= 10 \text{ mm} \\
 \sigma_{\max} &= 9.98 \text{ N/mm}^2
 \end{aligned}$$

3. Top Shaft

$$\begin{aligned}
 \sum M_a &= 0 \\
 R_a &= 49.03 \text{ N} & R_b &= 49.03 \text{ N} \\
 I &= 853.98 & Y_{\max} &= 10 \text{ mm} \\
 \sigma_{\max} &= 38.08 \text{ N/mm}^2
 \end{aligned}$$

IV- CONCLUSION

This system uses 3 different arrangement i.e. rope pulley mechanism, rack and pinion with moving rack and rack and pinion with stationary rack. So it is conclude that with the use of rope and pulley mechanism it is possible to lift system vertically so up and down movement is possible. Using rack and pinion mechanism with stationary rack and moving pinion.

It is possible that system can able to move with left and right movement. Finally with the use of rope and pulley mechanism with moving rack system can able to rotate with to and fro movement. This complete system works on 12v DC and 8amp. Battery system.

ACKNOWLEDGMENT

It is a matter of immense pleasure to acknowledge the debt of gratitude to our academic guru and renowned teacher, Prof. S. S. Gulhane for the unrelenting guidance and continuous encouragement in completion of this project work. The opportunity to work under such esteemed academician is a matter of great pride and privilege. The duration of project work has been very enlightening and has provided immense satisfaction to me/us.

We are thankful to Dr. Hemant S. Sonare, Director and Dr. S. A. Chavan, Principal GW CET, Nagpur and Prof. N. S. Chahande, H.O.D., Mechanical who have not only provided us with knowledge on different subjects in this B.E. program but above all, have also ignited my/our mind towards pursuance of engineering and technology. We would like to acknowledge our thanks to Prof. R. M. Bisen and other faculties of Mechanical Engineering

Department, GW CET, Nagpur for their constant encouragement regarding this project

REFERENCES

- [1] J.Bekker , *Multi-objective buffer space allocation with the cross-entropy method*, *International Journal of Simulation Modelling*, vol.12(1);2013. pp.50-61.
- [2] T. Berlec, J. Kusar, J Zerovnik, J. and M. Starbek ., *Optimization of a product batch quantity*, *Strojnicki vestnik –Journal of Mechanical Engineering*, vol.60(1), 014, pp.35-42.
- [3] H.J.Carlo, I.F.A. Vis, *Sequencing dynamic storage systems with multiple lifts and shuttles*, *International Journal of Production Economics*, vol.140(2), 2012, pp.844-853.
- [4] T.E. Erkan and G.F.Can, *Selecting the best warehouse data collecting system by using AHP and FAHP methods*, *Technical Gazette*, vol.21(1), 2014, pp87-93
- [5] T. Lerher, Y.B.Ekren, Z. Sariand B.Rosi, B, *Simulation analysis of shuttle based Storage and retrieval systems*, *Int j simul model*, vol.14(1), 2015, pp.48-59.
- [6] Kalyanaraman, Keerthika ,*A Review on Automated Storage/ Retrieval Systems and Shuttle Based Storage/Retrieval Systems*, *International Journal on Recent and Innovation Trends in Computing and Communication* ISSN: 2321-8169 Volume: 4Issue 11167–171
- [7] Divyesh Prafulla Ubale, Alan francy, N.P. Sherje *Design Analysis and Development of Multiutility home equipment using Scissor Lift Mechanism*, *IJSRM*, 2015.
- [8] Vitus M. Tabie, Yesueneagbe A. K. Fiagbe *Weight Optimization of a Lift-Tipping Mechanism for Small Solid Waste Collection Truck*, *IJSTR*, 2014.
- [9] Jovan Vladic, Petar Malešev, Rastislav Šostakov, Nikola Brkljač, *Dynamic Analysis of the Load Lifting Mechanisms*, *JME*.
- [10] C.Veeranjaneyulu, U. Hari Babu, *Design And Structural Analysis of Differential gear Box At Different Loads*, *IJAERS*, March 2013.
- [11] Haribaskar.G, Dhenesh Kumar.N, Arun Kumar .C, Hari Haran.P, Boobalan.M, Sadha Sivam., *Remote Controlled Scissor Jack to lift the Vehicle*, *International Journal of Advanced Research*, 2015.