

# Fault Analysis of Transformer by using PLC

**Mrunali Kite<sup>1</sup>, Urmila Chavhan<sup>2</sup>, Vaishnavi Choudhari<sup>3</sup>, Prashik Gajghate<sup>4</sup>, Rashmi Phasate<sup>1</sup>,  
Kiran Raut<sup>2</sup>**

*<sup>1</sup>UG student, <sup>2</sup>UG student, <sup>3</sup>UG student, <sup>4</sup>UG student, <sup>1</sup>Assistant professor, <sup>2</sup> Assistant professor.  
Dept. of Electrical Engineering, Shradha Park, B-37/39 Hingna- Wadi , Link Rd, Nagpur, Maharashtra 440028*

**Abstract** -. Transformers are critical and expensive component of the power system. As long time is required for repairing and replacement of transformer it is essential to innovate a system which is more reliable and efficient. This paper presents design and implementation of automatic control circuit which is used in PLC automation to monitor as well as diagnose condition of transformers like line current, transformer temperature and phase voltages. The PLC will help to detect the internal fault as well as external fault of transformer and also diagnose this fault with the help of desired range of parameters which is set by programmer. In proposed system with PLC relays and sensors are used to detect fault of transformer such as over voltage, under voltage, phase to phase fault and over temperature fault. Probability of faults on transformers undoubtedly more and hence protection of transformer is highly essential. The benefit of automation is it saves labor and save energy and material, improves quality, accuracy and precision, reduce dependency on human presence and decision making for any process. In this paper, the automation of transformer has been done by using PLC based system. In this system, various type of sensors and transducers are required for sensing various input parameter of transformer.

**Keywords-** Transformers, Faults , Failure s, Causes , PLC

## I. INTRODUCTION

**T**he transformers are electrical devices used for energy transfer by electromagnetic induction between two or more circuits. Like all electrical devices faults also happen in the transformers which cause failures. One failure can cause many problems. A simple fault at the distributing end can cause black-out of power to the whole area. The fault can also be very dangerous as the transformers contain large quantity of oil in direct contact with high voltage components. This increases the risk of fire and explosions due to failures. Different faults are caused by different reasons, which all have different impacts on the power system. In this paper some of the most commonly occurring failures are discussed with their causes and impacts. This important process of stepping-up and stepping-down of voltage and current is done by Transformers present at both ends of the power transmission and distribution. To avoid major line losses in power transmission over long distances the voltage is step-up to 11kv and the current is step-down as the power is transmitted to different parts of the country by long transmission lines. The losses are mathematically represented by Eq. 1:

$$\text{Losses} = I.I.R$$

Where I is current and R is the resistance. Longer the transmission-line more is the resistance. For this reason the voltage is kept high and the current is kept low. After power reaches its destination through the transmission lines, the voltage is step-down form 11kv to 220v and the current is step-up. In modern age, PLC automation has been placed on power reliability and economy. A power transformer is a very valuable and important link in a power transmission system.

A monitoring is essential to evaluate transformer performance and safe operating conditions. High reliability of the transformer is essential to avoid disturbances in transmission of power. Due to wide range of PLC automation, the various types of fault in power transformer can be detected and diagnosed by using PLC system. Some papers show that transformer protection a challenge to researchers. Monitoring it, is essential to avoid disturbance in transmission of power. Due to wide range of PLC automation the various types of fault in power transformer can be detected by using PLC system. One of the most effective methods of protection to protect power transformer is the differential protection method by using differential relay circuit. This scheme is based on the principle of that the power input to the transformer under normal condition is equal to power output..

### Programmable Logic Controller

A programmable logic controller (PLC) or programmable controller is an industrial digital computer. They were first developed in automobile manufacturing industry to provide flexible, easily programmable controller to replace hard wire relay, timer. PLC was discovered by the automotive industry to substitute the rewiring of the machine's control panel. PLC can range from small modular device with a 10 number of input and output in a housing integral with processor. They can be design for multiple arrangement of digital and analog I/O, extended temperature ranges, immunity to electrical noise and resistance to vibration. Programs to control machine operation are typically stored in battery backup or non-volatile memory.

The use of PLC in automation processes increases reliability, flexibility and reduction in production cost. Use of PLC interfaced with power converters, personal computers and other electric equipment makes industrial electric drive systems more accurate and efficient. PLCs have been gaining popularity on the factory floor and will probably remain preponderant in coming year.

## II .PROPOSED SCHEME

### Programmable Logic Controller

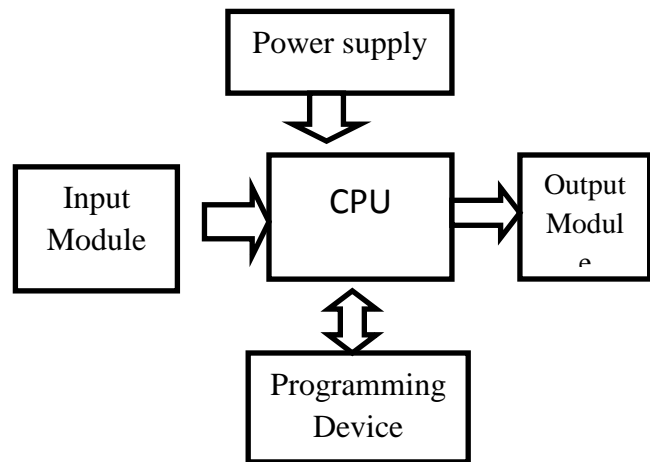

Fig 1: Block diagram of PLC

**a) CPU and Memory module:** - This is the device where PLC program is stored and processed. The size and type of CPU determines the programming functions available, size of the application logic available, amount of memory supports and supported and processing speed .CPU includes features like higher math functions, PID control loops and optional programming commands. The processor also consists of serial communication ports for printer, PLC LAN link and also external programming devices.

**b) Power supply:** The power supply given to a particular PLC depends upon the Manufacturers specifications. A power supply may be inbuilt processor module or a separate module. Common voltage levels required by the PLC are 24Vdc, 120Vac, 220Vac.

**c) Input and output modules:** Input and output modules are specified according to the requirements of a particular application. I/O can be either discrete, analog or register. Discrete I/O modules are capable of handling 8/16/32 ON-OFF type inputs or outputs per module. Analog I/O modules are specified according to desired resolution and voltage or current range. Pulsed inputs to the PLC are accepted through a high speed counter. Register I/O modules transfer 8 or 16 words (BCD or Binary) to and from the PLC.

**d) Programming Devices:** Programming device allows the engineer to enter and edit the program to be executed. More

advanced systems employ a personal computer which enables the programmer to write, view and edit the

program and download it to the PLC. This is accomplished using licensed software provided by the manufacturer. The software allows the programmer to simulate the program in real time scenario to determine proper operation. It also allows easy debugging of the program

III. HARDWARE EQUIPMENT

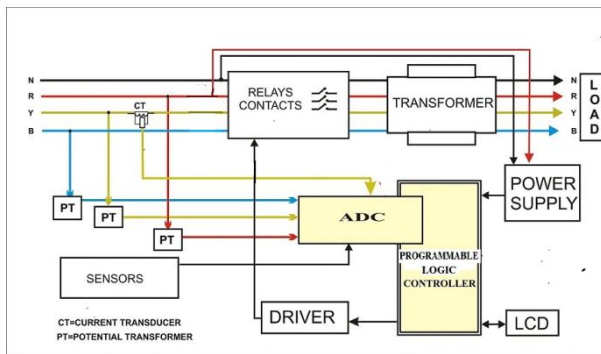

Fig2: block diagram of system

**Potential transformer-** PT’s are used to step down high voltage value to safer level to measure. This is because protective relay are low voltage devices, thereby cannot be connected directly through high voltage circuit. For the purpose of measurement and protection of the system . The rating of PT is 220/6 V.

**Current transformer-** A current transformer is a type of transformer that is used to measure alternating current. It produces a current in its secondary which is proportional to the current in its primary. The instrument transformer convert the large value of voltage or current to small , standardized value that are easy to handle for measuring instrument and protective relay. The rating of CT is 500/5.

Current transformer is the current sensing unit of the power system and is used at a generating station, electrical substation and in industrial and commercial electrical power distribution. CT is specified by their current ratio from primary to secondary. The rated secondary current is normally standardized at 1 or 5 A. For example: A 500/5 CT secondary winding will supply an output current of 5 A

.When the primary winding current is 500 A. Low voltage single ratio metering current transformer is either a ring type or plastic molded case.

**Relays:** Three simple electromechanical relays which are connected to three phases of primary winding of transformer. Each relay is placed on each phase of transformer. If anyone parameter crosses its level then PLC give signal to the relay, and system is disconnected from the supply. The rating of relay is 7A and 240 V.

**Single Phase Transformer (220V/12V):** It is used to step down the voltage of single phase transformer from 220V to 12V.

**Rectifier Circuit:** It is used to convert 12V AC to 12V DC. It consist of two Diode D1 and D2 which acts as a rectifier.

**Regulator IC 7805:** A voltage regulator IC maintains the output voltage at a constant value. It is used to convert 12V DC to 5V DC. Input voltage ranges from 7V to 35V.

Further, the PLC compares these digital signals with the settled overvoltage (265v) and under voltage (180v). If the signal is greater than 265 volt and less than 180 volt then the PLC gives command to relay and relay turn ON.

If in case of any phase failure the PLC treat this fault as a under voltage fault, because if any phase is not available that means the voltage is less than 180 v (0 volt is less than 180 volt) in this case also PLC give command to the relay.

**Temperature Sensor:** The Negative Temperature Coefficient (NTC) temperature sensor is used to detect precise centigrade temperature. The temperature can be detected from 0-120 degree C.

**Driver IC:** The PLC consist of a controller, this controller require 5 V supply and PLC is required 12 V supply. Hence amplifier IC is placed between controller and PLC which convert 5 V DC to 12 V DC.

**Power Supply:** Single phase 220 V AC supply is used.

RESULT:

Hardware Kit:

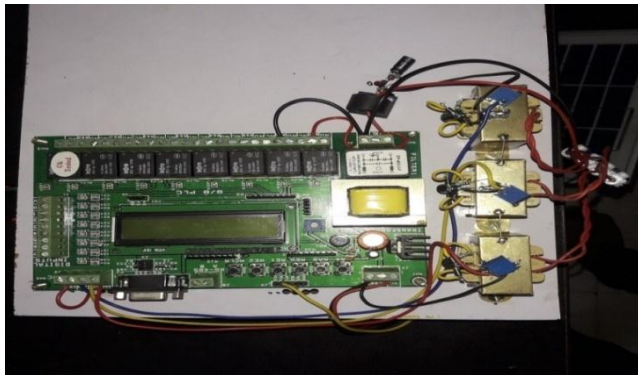

## CONCLUSION

**Under Normal Condition:** In normal condition all relay in off condition LED shows “ALL OK”. Fig. shows below.

In this paper we have presented a design of a system based on PLC that is used to monitor and control the voltage, current and temperature of a distribution transformer in both sides. The proposed PLC system which has been designed to monitor the transformers essential parameters . When the PLC recognizes any increase or decrease in the level of voltage, current or temperature values the unit has been made shutdown in order to prevent it from further damages with the help of relays in three phase system. The system not only controls the distribution transformer in the substation by shutting it down, but also displays the values throughout the process for user’s reference in SCADA system. This claims that the proposed design of the PLC system makes the distribution transformer more robust against some key power quality issues which make the voltage, current or temperature to peak. Hence the distribution is made more secure, reliable and highly efficient by means of the proposed system. PLC is used for monitoring the various parameters (voltage, current, temperature etc.).In normal operation all relays are in OFF condition. Suppose a fault occur at Y phase, then Relay present at Y phase is suddenly TURN ON and LED is TURN OFF as shown in image below. By using PLC, system operation & system reliability is improved.

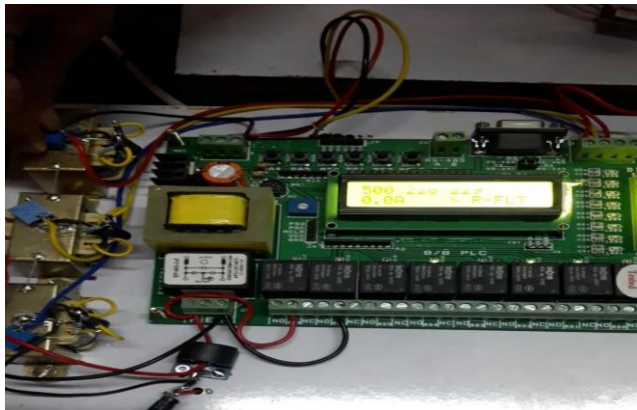

## REFERENCE

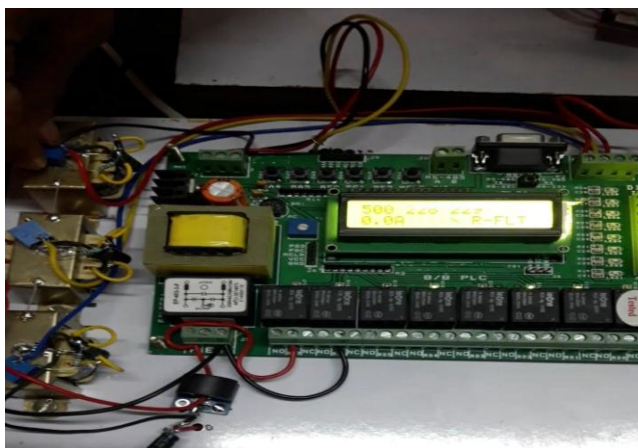

**Under Fault Condition:** If fault occur at phase R then relay at R phase is ON LCD show the “R FAULT”

- [1] J. F. Hopper, *Introduction of PLCs*, Carolina Academic Press, 2005.
- [2] W. Bolton, *Programmable Logic Controllers*, Newnes, 2015.
- [3] L. A. Bryan, E. A. Bryan, *Programmable Controllers: theory and implementation*, Industrial Text Company, 1997.
- [4] A.B. Gavali, S.A. Patil, A.R. Koli, “Technology-Based Learning system in Programmable Logic Controller Education”, 2016 IEEE Eighth International Conference on Technology for Education (T4E), 2016.
- [5] M. Asif, A. Raza, A. Sultan, F. Malik, “Design of Mini PLC based on PIC18F452 Microcontroller using Concepts of Graceful Degradation”, *Technical Journal University of Engineering and Technology Taxila*, Vol. 21, no.1, pp.51-57,2016.
- [6] I. Ahmed, S. Obermeier, S. Sudhakaran, V. Roussev, “Programmable Logic Controller Forensics”, *IEEE Security and Privacy*, Vol. 15, pp. 18-24, 2017.
- [7] I. Burhan, A. A. Azman, S. Talib, “Multiple I/O Programmable Logic Controller (PLC) module for education applications”, 2015 Innovation and Commercialization of Medical Electronic Technology Conference (ICMET), 2015.

- [8] Karpe S R, Sandip Shelar, Shradha Garkad, Shruti Lakade. “Fault Detection and Protection by Using Microcontroller.”, *International journal of modern trend in Engineering and Research*, www.ijmter.com Volume 02, issue03, March 2015, ISSN 2349-9745.
- [9] Sonwane Rupali, Wakode Kapil, Salve Dipika, Punde Sayali “Three Phase Transformer Fault Detection and Protection using PLC” ,*International journal for scientific Research & Development* ,Volume6, Issue02,2018,ISSN 2321-0613
- [10] Shubhangi Landge, Snehal Waydande, Sanjay Sangale, Somesh Gaikawad “Monitoring of Distribution Transformar Prameters using PLC,” *International research journal of Enginrering and Technology*, Volume04, Issue03, March 2017 , www.irjet.net .
- [11] Akshay Chilka, Abhishek Khapre, Prathamesh Narkhede. “Differential Protection for Power Transformer Using Microcontroller” *International Journal of Advanced Research in Electronics and Communication Engineering (IJARECE)*. Volume 5, Issue 5, May 2016.