

Microcontroller Based Smart Stick for Blind Person

Dr. R.A.Keswani¹, Krunal Thakre², Mayank Sharma², Mansing Dhirbassi², Nayan Mahilawar², Pratik Satpute², Praveg Meshram²

¹Associate Professor, Dept. of Electrical Engineering,
 Priyadarshini College of Engineering, Nagpur, India, 440019

²Students, Dept. of Electrical Engineering,
 Priyadarshini College of Engineering, Nagpur, India, 440019

Abstract-Blindness is frequently used to describe severe visual impairment with residual vision. It snatches the vivid beautiful view of the world from one's life. Along with this, one of the major problems is of transport, such as crossing roads, traveling in public transports and roaming in surroundings. They are always dependent on person and tools for such activities. They are uncomfortable to travel safely, confidently, and independently in the home and the community. Use of conventional stick has many disadvantages such as limited perception and lack of depth assessment. In this project, a system that overcomes the difficulties faced by the blind person has been proposed. This paper deals with design and implementation of a “Smart Blind Stick” which will help blind people to walk with ease and independently.

As of simpler version, better accuracy and assistance, three ultrasonic sensors i.e. vibrator, water level sensor, and GSM have been used in this project. The generally available blind walking sticks are capable of finding obstacle that touches the stick physically. In this paper, an advanced blind stick system that allows blind person to sense objects before stick touches them and check if there will be water in front is proposed.

Keywords- Walking stick, Microcontroller, Ultrasonic sensor, GSM module, Float detector, Vibrator motor, Buzzer.

I-INTRODUCTION

Blindness is one of the many issues people have no control on. According to a report by World Health Organization (WHO) [1] approximately 1.3 billion people around the world are living with some kind of visually impairment. However a more surprising fact is that out of these 1.3 billion people, 36 million people are completely blind. According to the report by Times of India, India is now home to the world's largest number of blind people. Of these 36 million people across the globe who are blind, over 15 million are from India [2]. On the other hand, while India needs 2.5 lakh donated eye every year, the country's 109 eye banks [3] manage to collect a maximum of just 25,000 eyes, 30% of which cannot be used.

In order to tackle above stated problems and empower 36 million blind people we are introducing a technological solution i.e. a “Smart Blind Stick” system using both hardware and programming for microcontroller which will help blind person to walk with ease and independently. We have implemented multiple sensors and indicator based system for helping and making blind person move independently.

We found that the main aids that blind people use are trained dogs, but such dogs are very expensive and not very reliable. Some other products available in the market are the smart belt, smart ring, smart cane etc. But these devices have very limited usability and lack approach due to more cost. So, blind people avoid buying such products.

Some innovators also tried to assist the blind people [4] using IR sensor, but researchers found that IR sensor cannot work in sunlight because it also contains some amount of infrared rays which can be detected by photodiode present in IR sensor.

To overcome such problems of an above research and innovation, a smart blind stick which uses ultrasonic sensors, a vibrator motor scheme, a controller and a power unit as a whole smart working unit is developed.

This paper, we were expected to tackle a real world problem. In a nutshell, we aimed at providing a technical solution to a real world problem which would help society in some form or the other, is provided. The purpose of this work is to identify ways and means to make the lives of blind people much easier. To be specific, this developed system will help blind people identify obstacles and make their next movement according to presence or absence of obstacle. Under many circumstances wherein the blind person may be confused about his next movement. In case of any emergency situation by pressing the electronic switch signal with location can be sent to his family member’s phone via an GSM application. In simple words it is emergency signals which the blind person sends to his family member.

It is not a herculean task to comprehend the amount of hardship which is inflicted upon these innocent souls. Even, many children are blind since birth and we must remember the fact that these children have a very long life ahead of them. Their lives can be improved significantly if their dependence is reduced to a considerable extent.

II- HARDWARE IMPLEMENTATION

A] COMPONENTS

Following table shows detail about components used:-

Sr. No.	Component	Description along with rating
1	Ultrasonic Sensor	An Ultrasonic sensor is a device that can measure the distance to an object by using sound waves. It measures distance by sending out a sound wave at a specific frequency and received a signal which return back to the sensor. 1. Voltage- 5 Volt 2. Distance- 2 cm to 250 cm 3. Angle Covered- 15° 4. Current – 15 mA 5. Frequency- 50 Hz
2	Microcontroller	Microcontroller is used to handle all the equipments to entire circuitry. We use microcontroller-ATMEGA 328P, in which ADC converter is already inbuilt to convert analog signal to digital signal. 5 Volt, 8 bit controller with 4/8/16/32k bytes in system, 3 timer/counter, 6 channel ADC converter.
3	GSM	GSM stands for ‘Global System for Mobile Communication’. GSM Module- SIM900D in our project sends out a SMS to family of blind person in case of trouble or being lost. 1. Range- 35 Km 2. Bandwidth- 1900 MHz 3. Voltage- 5 Volt

4	Vibrator Motor	Vibrator motor is a compact size dc motor used to inform the users of receiving the signal by vibrating. 1. Voltage- 12 Volt (DC) 2. Current – 0.06 Amp
5	Float Detector	A float detector is used to detect water on the way of the blind person as soon as the lower part of the system dips in water. Then buzzer will signal the blind person in different beep pattern receiving the signal by. 1. Voltage- 0-5 Volt 2. Current- 20 mA

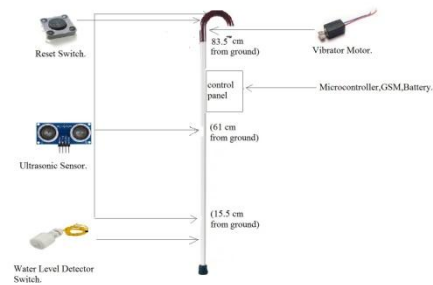

Figure 2:- Positioning of components

The proposed smart blind stick uses various controller based circuit to handle the entire system functioning. Three ultrasonic sensors are used in the circuit. One is connected at the top of the stick to detect the heightened object. Second is at middle to detect the middle range object and another one is at bottom of the stick to detect the lower object.

The very first idea is object detection and alert system. The obstacle detection is done using ultrasonic sensors. The sensors sense the nearby obstacles by using sonic technology. The microcontroller (ATMEGA 128P) processes the values generated by sensor and calculate the distance from the obstacle. If distance below threshold then alert signal is generated indicating the proximity of the obstacle. The noncontact measuring range for the ultrasonic module HC-SR04 is 2cm – 400 cm. The maximum ranging accuracy can be extended up to 3m. Ultrasonic sensor’s transmitter, receiver and control circuit is in the module. The working principle as follows:

1. IO trigger is used for at least 10 us high level signal.
2. Ultrasonic sensor module transmits 8 no of 40 kHz signal and detect if there is a pulse signal received back.
3. Though high level if the signal is back then time duration of high output is the measure of the time taken by the ultrasonic sensor from transmitting a pulse and receiving it back. It can be formulated as below,

$$\text{Test distance} = (\text{high level time} * \text{velocity of sound})/2.$$

B] BLOCK DIAGRAM

The block diagram showing various sensors used in smart blind stick is as shown in Fig.1 and exact mounting on the stick is depicted in Fig.2.

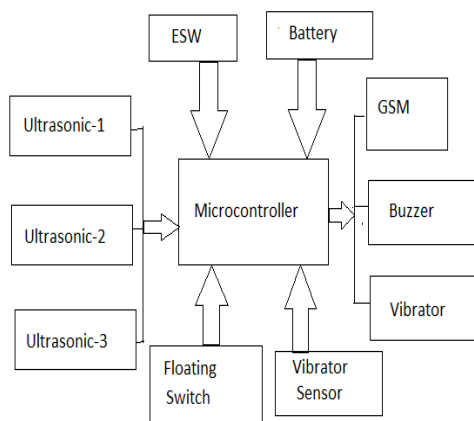

Figure 1:- Block Diagram of various sensor used

Also, float detector to detect water in front of the blind person is used. As soon as front wires of the system dips in the water, it will signal the blind person by different beep patterns. This system will also have a vibrator. As the ultrasonic sensor detects the obstacle, sound will beep and also the vibrator starts vibrating. If the stick falls down on the ground with some jerk it will be detected by the jerk sensor and the stick will start beeping. On detection of obstacle, the buzzer is sounded. Water sensors are also used. Water sensor will detect the presence of water and will send the information to the microcontroller in digital form, the microcontroller will analyze this data/information and will send the command to the user notification setup i.e. buzzer and vibrator according to our program to alert the blind person.

One more important feature of the system is that it allows the blind person to send out a SMS to the family in case of trouble or being lost. If the blind person feels uncomfortable with obstacle detection technology, he can switch to GSM based technique to get help from his family member or any friend. The change of this facility just takes place with a press of switch button provided on the stick. A notification is sent to the family member’s android phone indicating emergency help message from the blind person. The notification message includes distress signal by the blind person and the family member can contact him/her to navigate or to help. The buzzer is provided in a stick.

The various features of smart stick are:

1. It can sense obstacles like pebbles, pits, rocks etc.
2. It can sense water in the path to avoid slipping or drenching.
3. Stick can be easily located if misplaced.
4. It is also having a panic button; blind persons can immediately inform their relatives in case of an emergency.
5. It is cheap hence easy to afford by all potential beneficiaries.

The implemented circuit is designed in Proteus software as shown in Fig.3.

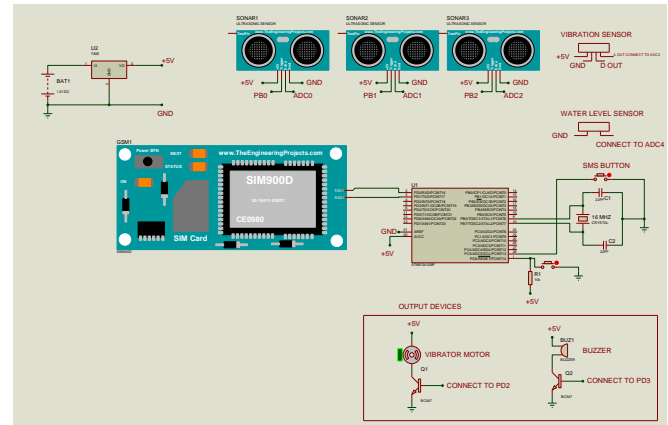

Figure 3:- Circuit Simulation in Proteus Software

In this circuit the 12V DC battery is used for GSM supply. The 12V DC supply is converted to 5V DC using voltage regulator IC 7805. We used the ultrasonic sensor HC-SR04. It has four pin GND, VCC, TRIG, ECO. The continuous clock pulse is given to the trigger pin. If the obstacle found in the range of ultrasonic sensor then the ECO pin will give the analog output. This analog output read by the microcontroller through the ADC pin of Microcontroller. As soon as the obstacle found microcontroller activate the buzzer and the vibrator motor. Buzzer will beep different as per the ultrasonic sensor reading. The SMS button in this circuit is used by the blind person when he/she is in danger then they will press this button and then microcontroller sends the SMS to the relative of the person.

III- CONCLUSION

The smart blind stick acts as a basic platform for the coming generation of more aiding devices to help the visually impaired to be more safe. This stick would have great impact on blind person’s day to day life. It is effective and afford. It leads to good results in detecting the obstacle lying ahead of the user also detecting stair and water. This system offers low cost, reliable, portable, low power consumption.

The limitation of this project was the ultrasonic sensor used can only detect the obstacle but cannot illustrate the shape of the obstacle.

The main target of this project is to assist blind or visually impaired people to move safely.

The advantage of this project, it can prove to be a very low cost solution to millions of blind people worldwide.

REFRIENCES

- [1] <https://www.who.int/news-room/fact-sheets/detail/blindness-and-visual-impairment>
- [2] <https://timesofindia.indiatimes.com/india/India-has-largest-blind-population/articleshow/2447603.cms>
- [3] <http://www.myeyeworld.com/files/eyebanks.htm>
- [4] Ayat A. Nada, Mahmoud A. Fakhr and Ahmed F. Seddik “Assistive Infrared Sensor Based Smart Stick for Blind People”, *Science and Information Conference (SAI)*, 2015, 10.1109/SAI.2015.7237289
- [5] Sarang Sharma, Manind Gupta, Amit Kumar, Meenakshi Tripathi, Manoj Singh Gaur, “Multiple Distance Sensors Based Smart Stick for Visually Impaired People”, in *Institute of Electrical and Electronics Engineers (IEEE) 7th Annual Conference on Computing and Communication Workshop and Conference (CCWC)*, on 9-11 January 2017 in Las Vegas, NV, USA.
- [6] Shashank Chaurasia, K. V. N Kavitha, “An Application of Infrared Sensor for Electronic Stick”, in *International Conference on Information Communication and Embedded Systems (ICES)*, on 27-28 Feb 2014 in Chennai, India.
- [8] P. Meijer, “An Experimental System for Auditory Image Representations”, *IEEE Transactions on Biomedical Engineering*, Vol.39, no. 2, pp. 112-121, Feb 1992.
- [9] World Health Organization, “Visual Impairment and Blindness”, *Fact sheet N “282”*, Oct 2014.
- [10] *National Disability Policy: A Progress Report - October 2014*, National Council on Disability, Oct 2014.
- [11] J.M. Hans du Buf, J.Barroso, Jojo M.F. Rodrigues, H.Paredes, M.Farrajota, H.Fernandes, J.Jos, V.Teixeira, M.Saleiro. “The SmartVision Navigation Prototype for Blind Users”. *International Journal of Digital Content Technology and its Applications*, Vol.5 No .5, pp. 351 – 361, May 2011.
- [12] I. Ulrich, and J. Borenstein, “The guide cane-Applying mobile robot technologies to assist the visually impaired,” *IEEE Transaction on Systems, Man, and Cybernetics-Part A: Systems and Humans*, vol. 31, no. 2, pp. 131-136, 2001.