

“Unsymmetrical Fault Analysis In Three Phase System With Auto Reset For Temporary Fault And Trip For Permanent Fault”

Pallavi Ponde¹, Karishma Chachire², Leenashree Walde³, Nidhi Oraon⁴, Pragati Pawar⁵,
 Pragati Parasgade⁶, P.S Gotekar⁷

⁷Assitant Professor,¹⁻⁶Students,
 Dept. of Electrical Engineering, Priyadarshini College of Engineering, Nagpur-440019

ABSTRACT -This project is to develop an automatic tripping mechanism for the three phase supply system. The project output resets automatically after a brief interruption in the event of temporary fault while it remains in tripped condition in case of permanent fault. The electrical substation which supply the power to the consumers, have failures due to some faults which can be temporary or permanent. These faults lead to substantial damage to the power system equipment. In India it is common, the faults might be LG (Line to Ground), LL (Line to Line), 3L (Three lines) in the supply systems and these faults in three phase supply system can affect the power system. To overcome this problem a system is built, which can sense these faults and automatically disconnects the supply to avoid large scale damage to the control gears in the grid sub-stations. This system is built using three single phase transformers which are wired in star input and star output, and 3 transformers are connected in delta connections, having input 220 volt and output at 12 volt. This concept low voltage testing of fault conditions is followed as it is not advisable to create on mains line. 555 timers are used for handling short duration and long duration fault conditions. A set of switches are used to create the LL, LG and in low voltage side, for activating the tripping mechanism. Short duration fault returns the supply to the load immediately called as temporary trip while long duration shall result in permanent trip.

Keywords—L-L fault, L-G fault.

I- INTRODUCTION

A fault in a power system is any failures which interferes with the normal flow of current. The cause of

electric power system faults is insulation breakdown. This breakdown can be due to a variety of different factors such as

- Lightning stroke
- Spray on Insulators
- Trees coming in contact with wires
- Equipment Failure
- Human Errors

As from the studies 70% to 90% of faults occur in overhead transmission line which are transient. There are many transient fault, such as damage of insulation, swinging wires and little time contact with other objects. These faults are cleared by operating the circuit breakers or can be cleared by de-energizing the line at short period for clearing the fault.

The other 30% to 10% faults occur in overhead line which are permanent or long duration fault. Permanent or long duration fault occurs by broken wire which results one phase to ground fault or joining the two phases together which is occurred in overhead line as well as in the underground cable. These faults are cleared by finding them in line and repaired.

The faults can be classified into:

- Symmetrical faults
- Unsymmetrical faults

The Shunt faults are characterized by increase in current and fall in voltage and frequency. The Shunt faults can be classified as:

- Single Line to Ground (LG) fault
- Line to Line (LL) fault
- Double line to ground (LLG) fault
- Three Phase fault

An unbalanced fault does not affect each of the three phases equally. Common type of unbalanced fault and there causes:

- Line-to-Line (LL) fault: A short circuit between lines, caused by ionization of air, or when lines come into physical contact, for example due to a broken insulator.
- Single line-to-ground (LG) fault: A short circuit between one line & ground, very often caused by physical contact, for example due to lightning or other damages.
- Double line-to-line ground (LLG) fault: Two lines come into contact with the ground also commonly due to storm damage which results permanent trip of line

II- WORKING

There are six step down transformers which are connected to the board producing 12 volts to the circuit. These six transformers are divided into two groups, first one group is connected in star-star connection and later s connected in star-delta connection. The output of all the six transformers are rectified and filtered individually and are given to 6 relay coils. 6 push buttons one each connected across the relay coil is meant to create a fault condition.

The NC contacts of all the relay are made parallel while all the common points are grounded. The parallel connected point of NC is then connected to pin2 of 555 timer through a resistor R5 i.e. wired in monostable mode the output (pin3) of the same timer is connected to reset (pin4) of the other 555 timer wired in astable mode. LED’s are connected at their output to indicate their status.

The output (pin1) of 555 timer (U3) is given to op-amp LM358 through wire 11 and d12 (1N4007) to the non-inverting input (pin3) which acts as a comparator. It compares the value of pin 2 (inverting input) and pin 3 (non-inverting input) of LM358.

The voltage of pin 2 is kept at fixed/constant voltage with the help of potential divider. It is generally kept higher than the pin 3 of operational amplifier so that pin 1 i.e. output of LM358 develops low (zero logic) which fails to operate 3CO relay through the transistor Q, and the same is used for disconnecting the load used in fault condition

III- BLOCK DIAGRAM

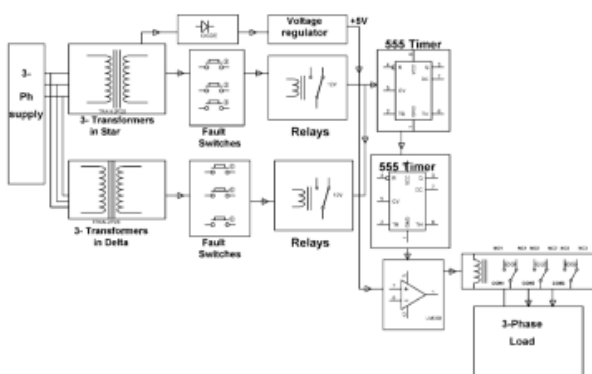

Fig. 1

IV- COMPONENTS REQUIRED

- Transformer(230V-12V)
- Relays
- Comparator(LM358)
- 555 Timer
- Voltage Regulator (LM7805)

V- OPERATING PROCEDURE

Transformers and Lamp Bulbs are connected along with Three Phase Power Supply (230V). After the board is powered by 3 phase supply, all relay coils get DC voltage and due to this the common points Disconnects from NC contacts and moves to the NO contacts. When push buttons are pressed, it disconnects the relay and due to this the common points moves to the NC position to provide a logic low at a trigger pin (Pin 2) and the output (Pin 3) which is linked to reset pin (Pin 4) develops high logic indicated by D11 flashing LED of 555 Timer (u3) which is in Astable Mode. -If fault is temporary If any push button is released after a short time, 555 Timer (U1) in Monostable Mode disables U3 due to which the output of U3 goes to zero. -If fault is permanent If any push button is pressed for a longer Duration, then the output of 555 Timer (U3) present in Monostable Mode provides a longer duration of active situation for 555 Timer (U3), output of the same charges the capacitor C13 through R11. The output (Pin 1) of Operational Amplifier (LM 358), though acting like a comparator gets high which in turn drives the 3 CO relay through transistor Q1 to switch off 3 phase load.

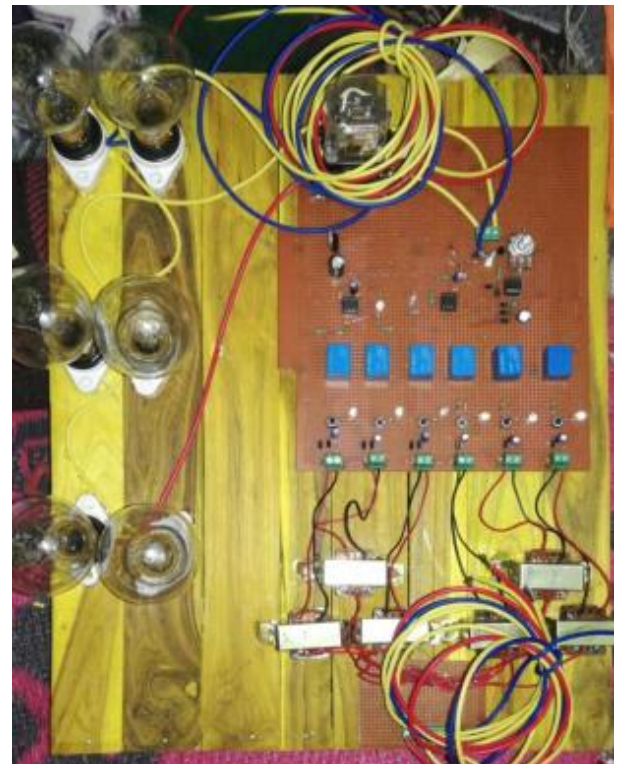

Fig. 2- Practical Circuit of Fault Analysis

VI- APPLICATION

- Applied in transmission and distribution system.
- Used in substation.
- For clearing temporary fault in industries and commercial sectors
- Apartments

VII- CONCLUSION AND FUTURE SCOPE

L-G and L-L faults have been created to develop an automatic tripping mechanism for the three phase supply system while temporary and permanent fault occur. Here timer 555 has been used with relay for the fault analysis short duration fault returns the supply to the load immediately called a temporary trip while long duration shall result in permanent trip as this project is advantageous compare to other protection system it can be used for protection of transmission line faults which occur in power system hence this system is more economical, automatic and hazards free compared to other type of protecting system against three phase fault. In future following modifications can be done: • In next some years GSM service can be added in this system to know consumer , when fault occurred. • The fault is automatically detected but by extending this we can automatically clear the fault in future.

REFERENCE

- 1) *Protection Relay Application Guide; GEC Measurement, 1975*
- 2) Nagar D. Singh, Bhalla D Paliwal; “Three Phase Auto Re-closer Scheme”; *IJSRD –International Journal for Scientific Research & Development*; 2016 volume : 4 (Online) pp: 2321-613
- 3) Sathish Bakanagari, A. Mahesh Kumar, M .Cheenya ; “Three Phase Fault Analysis with Auto Reset for Temporary Fault and Trip for Permanent Fault”, *Journal of Engineering Research and Applications*; ISSN: 2248-9622, Vol. 3, Issue 6, Nov-Dec 2013, pp. 1082-1086.
- 4) Robert L. Boylestad, Louis Nashelsky, “*Electronic Devices and Circuit Theory*”, Tenth Edition, Pearson Publication.
- 5) Ramakant A. Gayakwad, “*OP-AMPS And Linear Integrated Circuits*”, Third Edition, Prentice-Hall India Publication.
- 6) D.P Kothari, I.J Nagrath, “*Power System Engineering*”, Second Edition, The McGraw Hill Companies.
- 7) Chakrabarti, M.L. Soni, U.S. Bhatnagar, P.V. Gupta, “*A Textbook on Power System Engineering*”, Second Edition, Dhanpath Rai Publications.
- 8) Jun Zhu, “*Analysis of Transmission System Faults the Phase Domain*”, Texas A&M University, Master Thesis, 2004.
- 9) Miroslav D. Markovic, “*Fault Analysis in Power Systems by using the Fortescue Method*”, TESLA Institute, 2009.