

Home Automation Using Iot

Nidhi Jha¹, Sanvedita Deshpande², Sanskruti Chidrewar³

Dy Patil College of engineering, Akurdi , Pune

nidhijha1605@gmail.com

Received on: 11 June ,2022

Revised on: 10 August ,2022,

Published on: 14 August,2022

Abstract- The concept of Internet of Things (IoT) requires the seamless connectivity of millions of heterogeneous devices. In today's World, implementation of IoT based smart home has drawn a huge attraction and become a prominent area of research. This research work presents an approach for smart home automation using IoT that can be controlled wirelessly. Home automation system means monitoring and controlling of home appliances remotely using the concept of internet of things (IOT). In this method we use mobiles or computers to control the basic home appliance and make it function through the designed web page with internet connection/local area network (LAN) servers. This type of home is also known as smart home. The concept of applying automation in the sectors of housing is selling like hot cake. Western countries have welcomed the concept of automation into their homes with open arms. Our country is keeping up with the pace of modernization too. Different approaches to automating homes have been implemented. The best among this is home automation system using IOT. IOT provides the feasibility of operating the home automation system from anywhere around the world using internet. It reduces use of excessive or unnecessary human efforts and improves the standard of living of the people in India.

Keywords: IoT, local area network

I- INTRODUCTION

IoT-based smart home automation systems are designed to monitor and control the attributes you want to manage. For example, a range of Wi-Fi devices collects and shares data via Internet protocols. In turn, each device has sensors or detectors reporting to a central home automation hub. In such a way, sensors transmit and receive commands to one

or several hubs to further communicate the output to the cloud network. The presented architecture allows personal devices to be part of this system remotely.

A. Arduino mega 2560:

The Arduino Mega 2560 is a microcontroller board based on the ATmega2560. It has 54 digital input/output pins (of which 15 can be used as PWM outputs), 16 analog inputs, 4 UARTs (hardware serial ports), a 16 MHz crystal oscillator, a USB connection, a power jack, an ICSP header, and a reset button. It contains everything needed to support the microcontroller; simply connect it to a computer with a USB cable or power it with a AC-to-DC adapter or battery to get started. The Mega 2560 board is compatible with most shields designed for the Uno and the former boards Duemilanove or Diecimila.

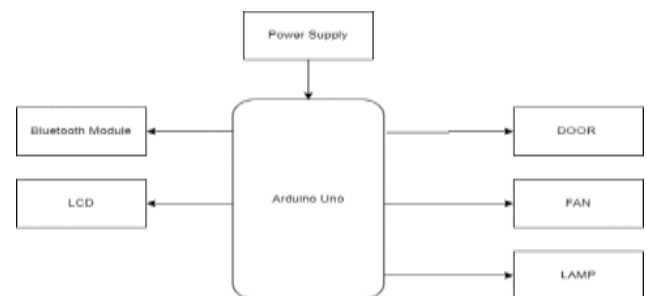

Fig 1- Block Diagram

A. LCD:

Liquid Crystal Display," which is generally used in computer monitors, instrument panels, cell phones, digital cameras, TVs, laptops, tablets, and calculators. It is a thin display device that offers support for large resolutions and better picture quality. The older CRT display technology

has replaced by LCDs, and new display technologies like OLEDs have started to replace LCDs. An LCD display is most commonly found with Dell laptop computers and is available as an active- matrix, passive- matrix, or dual-scan display. The picture is an example of an LCD computer monitor.

C- Bluetooth

Bluetooth is a short-range wireless technology standard that is used for exchanging data between fixed and mobile devices over short distances using UHF radio waves in the ISM bands, from 2.402GHz to 2.48 GHz, and building personal area.

D-Door

Door is a hinged or otherwise movable barrier that allows ingress into and egress from an enclosure. The created opening in the wall is a doorway or portal. A door's essential and primary purpose is to provide security by controlling access to the doorway (portal). Conventionally, it is a panel that fits into the portal of a building, room, or vehicle. Doors are generally made of a material suited to the door's task. Doors are commonly attached by hinges, but can move by other means, such as slides or counterbalancing.

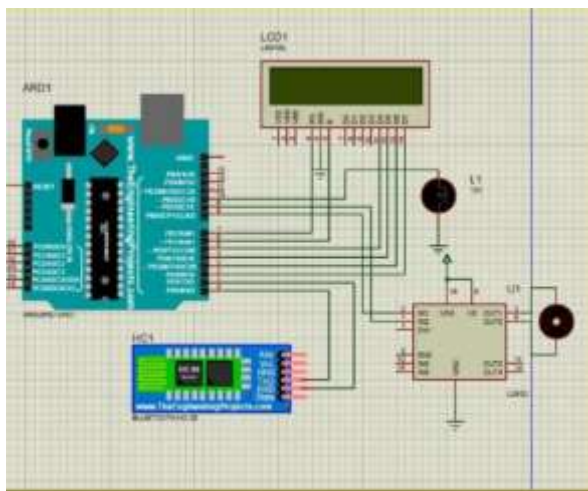

• Hardware features:

1. Typical -80dBm sensitivity Up to +4dBm RF transmit power.
2. Low Power 1.8V Operation, 1.8 to 3.6V I/O PIO control.
3. UART interface with programmable baud rate.
4. With integrated antenna with edge connector.

• Software features:

1. Default Baud rate: 38400, Data bits: 8, Stop bit: 1, Parity: No parity, Data control: has. Supported baud rate: 9600,19200,38400,57600,115200,230400,460800.
2. Given a rising pulse in PIO0, device will be disconnected. Status instruction port PIO1: low-disconnected, high-connected.
3. PIO10 and PIO11 can be connected to red and blue led separately. When master and slave are paired, red and blue led blinks 1time/2s in interval, while disconnected only.
4. Blue led blinks 2 times.
5. Auto-connect to the last device on power as default.
6. Permit pairing device to connect as default.
7. Auto-pairing PINCODE: "0000" as default.
8. Auto-reconnect in 30 min when disconnected as a result of beyond the range of connection.

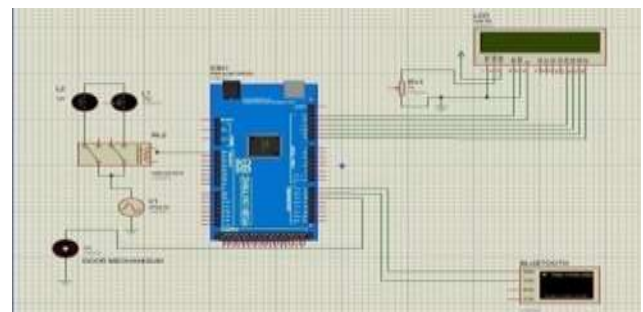

The main components of Home and Door Automation purpose are Atmega328, Bluetooth module, Motor driver, DC motor.

Required

- Arduino mega 2560
- Motor driver circuit (IC – L293D)
- Bluetooth module
- DC motor
- L293d
- Connecting wires
- 9-volt battery 8.100K 330kResistor
- 9.330K resistor
- 0.122uf Cap
- Mobile phone LEDs



Vee Hoong” Smart GSM Based Home Automation System”, 2013, *IEEE Conference on Systems, Process Control, Kuala Lumpur, Malaysia*.

[4] M.Van Der Werff, X. Gui and W.L. Xu,” A Mobile based Home Automation System, Applications and Systems”, 2005, 2nd *International Conference on Mobile Technology, Guangzhou, pp.5*.

[5] Mahesh. N. Jivani,” GSM Based Home Automation System Using App-Inventor for Android Mobile Phone” 2014, *International Journal of Advanced Research in- Electrical, Electronics and Instrumentation Engineering, Vol. 3(9), pp. 1212112128*.

CONCLUSION AND FUTURE WORK

Changing the way of the automated notifications by using the android application to make this system more professional. This system can be modelled into an IOT device by minor changes.

REFERENCES

- [1] Baris Yuksekkaya, A. Alper Kayalar, M. Bilgehan Tosun, M. Kaan Ozcan, and Ali Ziya Alkar” A GSM, Internet and Speech Controlled Wireless Interactive Home Automation System”, 2006, *IEEE Transactions on Consumer Electronics, Vol. 52(3), pp. 837 - 843*.
- [2] Rozita Teymourzadeh, Salah Addin Ahmed Kok Wai Chan and Mok Vee Hoong” Smart GSM Based Home Automation System”, 2013, *IEEE Conference on Systems, Process Control, Kuala Lumpur, Malaysia..*
- [3] A. Alherbish,” Design and implementation of Home Automation System”, 2004, *IEEE Transactions on Consumer Electronics, Vol. 50(4), pp. 10871092.2*] Rozita Teymourzadeh, Salah Addin Ahmed Kok Wai Chan and Mok