

Military Spying Robot

Vijay Narayan Mahajan¹, Rushikesh Madhavrao Patil², Prafull Narayan Patil³,
Shubham Subhash Patil⁴

^{1,2,3,4} UG student, , GF's Godavari College of Engineering, Jalgaon India, 45001

vijumahajan00@gmail.com

Received on: 20 April, 2023

Revised on: 14 May, 2023

Published on: 16 May, 2023

Abstract –This system is designed to reduce casualties in terrorist attacks like the one that took place on November 26th. This problem can then be overcome by developing a spy robot based on it that uses wireless technology, making it easier to investigate competitors if necessary. This robot can silently enter enemy territory and send us information through sensors. Robotics has been the backbone of advanced manufacturing for over half a century. Mobile robotics are playing an increasingly important role in military affairs, from patrolling to dealing with potential explosives. The currently most popular gadget is the Android smartphone. There are many applications on the internet that use the built-in hardware such as Bluetooth in these mobile phones to control other devices. With the development of modern technology and Android smartphones, Bluetooth technology aims to exchange data wirelessly over short distances via radio transmission, including the functions of convenience, perception and control. Here we have designed a robot that can be controlled by an app running on an Android phone. Send control commands via Bluetooth connected to the controller. The controller can be connected to the Bluetooth module via the UART protocol. The movement of the robot can be controlled according to the commands received from the android. Therefore, the necessary measures can be taken. This project introduces a useful application with a real-time object detection system that can automatically detect user-defined important objects. By identifying these custom objects,

we will immediately separate them with a robot. The problem discussed in this article is solved by detecting and using objects with defined sensors. We would also like to introduce an integrated technique for detection and detection of objects in real time.

Keywords-PICs, RF, spy robot, metal detector, ultrasonic detector

I - INTRODUCTION

In this system, mine clearance technicians and operations managers face a variety of challenges, including high risks. A typical mine clearance mission consists first of all in surveying an area with a remote-controlled robot and clearing a mine. The system also includes a night vision camera, which allows you to see not only what is being recorded during the day, but also at night. The entire system is controlled via an Android app. The Android smartphone acts as a remote control device to move the robot. An Android application is being developed for this purpose. The Bluetooth module acts as an interface between the smartphone and Arduino. [1] This robot can silently enter enemy territory and send us information via a wireless camera. Robotics has been the backbone of advanced manufacturing for over half a century. In the system we use a Bluetooth module that can act as a master or slave. In general, our master will be a smartphone and a slave. As robots and their peripherals become more sophisticated, reliable,

and miniaturized, these systems are increasingly being used for military and law enforcement purposes.[2] The purpose of building a robot is to encourage people by ensuring safety. The innovations used in this protection and containment robot have several significant advantages such as: B. the mechanical control of the vehicle via HF and Wi-Fi technology, naturally maintaining a strategic distance from obstacles in its path. A long-range, large-caliber camera equipped by law enforcement monitors the suburbs in adverse conditions. You get support from The controller is programmed with built-inEmbeddedC programming.In addition, we also have an ultrasonic sensor and a metal detector for detection. The ultimate focus of this facility is to provide the person with the ultimate security [3].

II- LITERATURE REVIEW

This research paper is based on Spying Robot made using various technologies and sources. This article is essentially based on a project we created. Army personnel or units face many dangers when spying on enemy or opposing units. To overcome these ideas, this robotic profession will be more suitable and reduce the risk of fatalities and be able to better spy on the illegal maneuvers of his enemy units. Before entering the questionable quarters, we can send a robot to check the status of this camp so that the soldiers don't have to risk their lives. These types of robots are built in such a way that The main purpose of developing this robot is to observe human activity on the battlefield or in frontier regions in order to limit enemy infiltration.The military risked their lives by entering uncharted territory. The robot will serve as a suitable machine for the defense industry to reduce human casualties and prevent illegal activities. This will help all armed and military forces to know the state of the territory before entering it. This innovative system is designed for operations with a high risk of human interference, especially in some criminal cases, and can be very useful in military areas for espionage purposes.This system saves the precious lives of our soldiers. This system uses a robotic arm and vehicle to enter military terrain. The entire system is controlled via an Android app. In the event of a military liquidation, the client connects to the server via a TCP/IP connection. Once the client connects to the server, it can send commands to move the robot forward, backward, left, and right.. This robot is used to clarify short separations for site security. The structure consists of a vehicle equipped with an inspection camera with RF innovation for long-distance operation. The sender sends instructions to the receiver on how to control the

development of the robot. The collector collects and disentangles the previously received flags by amplifying the microcontroller that controls the motors through the controllers.The camera remote control can transmit live audio and videorecordings to a computer or TV via a tuner card on the remote control station. Today's military uses different types of robots for a variety of applications, from mine detection to rescue drills. In the future, they will be used for perception and observation, coordination and support, building correspondences, transferring to enemy exercises and as strategic fakes to cover the movement by observation resources

III - METHODOLOGY

The system works by first sending commands to the receiver via the remote control, which are then processed and sent to the control circuits that move the motors. Then commands are transmitted to the camera motor and rare wheel motors, which move accordingly. The shots obtained with the program are transferred in real time to the camera's capture card and then displayed on the screen. The modified PIC microcontroller uses a special core coding. The PLC pins PORT A and PORT B are used as input and output pins. The PORT A pins of the 6F628 SPS are simply connected to the remote control. The 6F877 PORT B PLC pins are connected to the L2980 motor driver. RB 7 is used for the serial communication input and output pins and has a baud rate of 9600.This program also has the ability to execute send and receive commands.

IV- DESIGNAND WORKING

There are several remote control spy robots, the spy robot also has an ultrasonic sensor metal detector and a gas detector, and also provides information to the mediation group or spy group. The size of these types of robots is usually small enough to move around more efficiently. The task that we have to do, we have a mobile military intermediary or a spy robot that we control remotely, we used it. Arduino Uno Temperature Sensor Ultrasonic Sensor These kinds of robots are designed to operate secretly, which are also controlled by remote control, battery, antenna. We used two different PICs to control the robot and the whole system with one remote control.In our robot we also used it to block any information or data about the robot. On our remote control. The RF module (high frequency modules) is also used in this robot to receive signals from the remote controller and transmit them to the acting robot, allowing the user to control the speed of the robot, basically giving the robot full control over the

robot gives . In order to have good speed and rotation control, we used brushed DC motors (three) with a L2989 motor driver (two) in our military agent robot.

A. Arduino Uno

The Arduino UNO is a standard Arduino board. It was named UNO to mark the first version of the Arduino software. It is considered as a powerful board used in various Arduino projects. Arduino UNO is based on ATmega328P microcontrollers. It is easier to use than other boards like Arduino Mega Board etc. The board consists of digital and analog input/output (I/O) pins, shields and other circuitry. The is programmed on the basis of IDE, which stands for Integrated Development enviroment

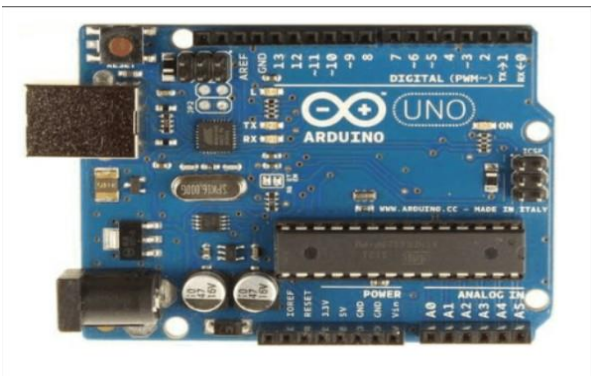

B. Ultrasonic Sensor

An ultrasonic sensor is an instrument that uses ultrasonic waves to measure the distance to an object. High-frequency sound waves bounce off the boundaries, creating distinct echo patterns. How the Ultrasonic Sensor Works: Ultrasonic sensors work by emitting a sound wave at a frequency at that time is above the range of human hearing. The pickup transducer acts as a microphone for receiving and transmitting ultrasonic tones. Our ultrasonic sensors, like many others, use a single transducer to send an impulse and receive an echo.



ULTRASONIC SENSOR

C. Remote control:

The remote control consists of a Bluetooth-enabled mobile phone that is used for management information headers. There is an antenna that is used to receive and transmit signals. The remote power supply should control the entire system. It houses the remote control circuitry and also a radio frequency module is implanted in the remote control to communicate with the robot. The LM7805 voltage regulator is used to control the PIC 16F628A microcontroller. This voltage regulator is very suitable for controlling constant potential voltage, it also connects to the battery. The remote control emits the signals and the RF module individually. information to the spy robot, which will be picked up by the RF receiver. As you can see in figure 5, the whole driver circuit

D. Robot Vehicle

This complete military spy robot consists of Aurdinio One, we have four wheels, three brushed DC motors, two L2989, one RF module, two LM7805 and one microcontroller. The microcontroller, which is the PLC we have, has forty pins to power the robot. An L is only used for this PIC to provide a constant +5V to the microcontroller. Using PIC 16F877 is not only a communication between the system and the RF module, but also the command to the motor controller to move the robot very precisely along the path or functional road. Accuracy is very important with these robots. In our robot, it consists of three DC brush motors with a power source. To run these motors we need motor drivers and we used motor drivers. We used two of these for brushed DC motors and in our robot, as mentioned, we used brushed DC motors, each motor connected to a wheel. Each wheel can move forwards and backwards thanks to the ability to reverse the rotation of the brushed DC motors. A DC motor assembly is connected to the project's motion controller. And the second set is assembled on the go. There are also two left and right limit switches connected to the spindle on which it moves to control its movement. When the camera interacts with a limit switch it will stop moving, U-Turn Mastery will not work on contact with a limit switch.

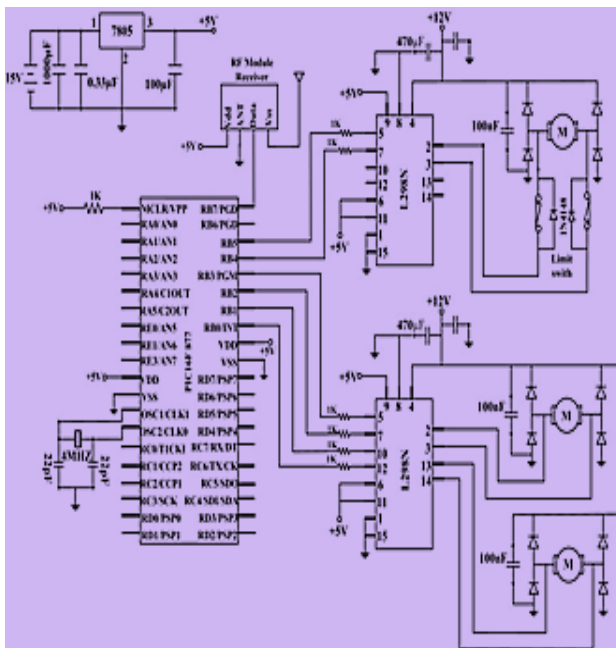

Fig - Robot vehicle circuit

V- RESULT & DISCUSSION

This complete military spy robot consists of Aurdinio One, we have four wheels, three brushed DC motors, two L2989, one RF module, two LM7805 and one microcontroller. The microcontroller, which is the PIC we have, has forty pins to power the robot. An L is only used for this PIC to provide a constant +5V to the microcontroller. Using PIC 16F877 is not only a communication between the system and the RF module, but also the command to the motor controller to move the robot very precisely along the these robots. In our robot, it consists of three DC brush motors with a power source. To run these motors we need motor drivers and we used motor drivers. We used two of these for brushed DC motors and in our robot, as mentioned, we used brushed DC motors, each motor connected to a wheel. Each wheel can move forwards and backwards thanks to the ability to reverse the rotation of the brushed DC motors. A DC motor assembly is connected to the project's motion controller. And the second set is assembled on the go. There are also two left and right limit switches connected to the spindle on which it moves to control its movement. When the camera interacts with a limit switch it will stop moving, U-Turn Mastery will not work on contact with a limit switch.

VI- CONCLUSION

The smartphone is Android, which can develop an effective remote control program. At the same time, this

program uses a Bluetooth connection to communicate with the robot. It has been shown to allow meaningful two-way communication between an Android phone and a robot. The multitasking military robot will be designed to meet the needs of army, police and armed forces. It has countless uses and can be deployed in a variety of environments and scenarios. For example, in one location it may be used by the military for military purposes, while in another location it may be used for espionage. Once located, it will also be able to disperse mines, such as by shaking them, collapsing buildings, and traversing mining areas

FUTURE SCOPE

The future purpose is a military spy robot. In times of war, it can be used to gather information in a safe remote area and develop a counterattack plan in a safe remote DP, and it can make it more useful by consuming more operation routines and modules like wifi module, raspberry pi. The future range of this robot is very powerful, it can have gas sensors to detect harmful or dangerous gases in the environment. It can also be used as a bomb scatterer and the bomb disposal team can also use this type of robot in many ways and reduce the risk factor of losing people. Additionally, a target frame can be attached to the robot to shoot any enemy when spotted. Innovation can be further encouraged by offering advice on acceptance and circuit control via satellite correspondence. It is used in shopping centers for vans, dump trucks and vehicle paints. Likewise, the framework can be based on Android, whereby the entire control should be possible with a high-end mobile phone. There is a light called a halogen light that is useful for seeing the camera attached to the robot. This robot can also be controlled by giving commands, it also detects harmful gases and enemies, which will be very useful for spying and detection.

REFERENCES

- [1] *Arduino-controlled spy robot on a warfield with a wireless night vision camera and an Android app.* Patel Charotar University of Science and Technology, Changa, Anand, Gujarat, India
- [2] *Robot-Spia auf dem Feld der Guerra mitdrahtleserTelekamerafürNotturma International Journal for Research in Applied Science Engineering Technology (IJRASET) ISSN: 2321-9653 ; Wert IC: 45,98; Auflage SJ: 6.887 Band 5 Nummer XII December 2017 Autor: Priyanka Yadav, Leena Chaudhari, Swati Gawhale Bharati Vidyapeeth College of Engineering, Lavale, India.*

- [3] *Robot mobile di salvataggio and sicurezzatelecomandato*, GolapKantiDey, RaqibulHossen, Md. Shafayet Noor, KaziTanvirAhmmmed, *IEEE* 2013
- [4] *Robot spiacontrollato from Arduino with telecamera per visionenotturna wireless e app Android*, JigneshPatoliya, Haard Mehta , Hitesh Patel, *5th Nirma University International Engineering Conference (NUiCONE)*
- [5] *Robot spia auf dem Feld der Guerra mit wireless Telekamera*, KunjGudhka, AishwaryaKadam, Devika Kale, ManilRupani, Prof.TilottamaDhake, *International Journal of Electrical and Electronic Research ISSN 2348-6988 (in linea) vol. 4, Nummer 1, S. (85-92), Monate: Januar - März 2016.*
- [6] *CONTROL OF ROBOS USING SMARTPHONES FOR MONITORING APPLICATIONS*,:03 Ausgabe: 3. März 2014.
- [7] *Military Spying and Bombing Robot with IOT*, 1CHAITRALI JADHAV, 2SHAMLI GIBILE, 3SNEHAL GAIKWAD, 4NEELUM DAVE, *International Research Journal of Engineering and Technology (IRJET) e-ISSN: 2395-005 Band : 05 Edizione: 04 aprile 2018.*
- [8] *PROGETTAZIONE E IMPLEMENTAZIONE DI UN SISTEMA DI CONTROLLO REMOTO PER ROBOT SPIA*, *International Journal of (IJSETR), Band*
- [9] *8051 Microcontroller and Embedded System Using Assembler and C, Issue 2 (ISBN: 9780131194021) von MazidiMuhammad Ali (2008).*
- [10] *M. Selvam, "Smartphone-Based Robot Control for Surveillance Applications", IJRET, Band 3, Ausgabe 3, S. 229-232, März 2014.*