

Hardware and Simulation of PV Based Fuzzy Logic Algorithm MPPT with Grid Connected System

Nayana Chaurpagar

M.Tech Student, Wainganga College of Engineering and Management Nagpur, Maharashtra, India 441108

chaurpagar97@gmail.com

Received on: 10 April ,2022

Revised on: 16 May ,2022,

Published on: 18 May,2022

Abstract: During times of financial crisis power demand has been increasing day by day. Whereas, increasing in pollution with growing population focusing on renewable energy source can make huge impact to control pollution. In order to deal with increase in power demand an efficient photovoltaic power generation system needs to develop. Photovoltaic (PV) system has witnessed a rapid increment, the yield mainly relies on the working condition. In most cases, it is hard to obtain the optimal yield. Therefore, maximum power point trackers are so important in PV system to increase their efficiency. To extract maximum power from photovoltaic under different weather conditions MPPT techniques have been proposed. The system has been experienced under disturbance in the photovoltaic temperature and irradiation level. An intelligent technique of maximum power point tracking (MPPT) based on Fuzzy logic controller (FLC) is examined. Simulation is carried for this method under all environmental conditions. The duty cycle of the DC-to-DC boost converter is controlled by the fuzzy MPPT control technique. Satisfying all the conditions of synchronization for photovoltaic system connected to grid.

Keyword- Photovoltaic system, Maximum power point tracking (MPPT), Fuzzy logic controller (FLC), DC-to-DC boost converter, inverter, grid.

I- INTRODUCTION

Observing from few decades, energy has great importance for daily life and economy. Due to industrial revolution energy demand has greatly increased. To

satisfy this requirement, renewable energy source is considered as a technological option for generating clean energy. Among them, the photovoltaic (PV) system has taken great attention by the research. However, it has less efficiency of power generation the effective system maximum power point tracking (MPPT) is installed. It has an ability to extract maximum power from PV array to increase utilization efficiency of solar energy. Generally, the MPPT is adopted to track maximum point in PV system but the efficiency of MPPT is depend upon both the MPPT technique and MPPT circuit. Considering all the techniques of MPPT, intelligent technique provides fast response under any operating conditions. Also, it provides accurate results and can work under any instant temperature and variable solar irradiation. Thus, Fuzzy Logic Controller (FLC) based MPPT technique is used for accurate results and fast response. FLC does not require pre-knowledge of exact model. The performance of FLC is evaluated by MATLAB/Simulink.

DC-DC converter in photovoltaic power generation is used as interface between solar panel and load. Converter is used for stabilized the changing voltage from PV array and step-up the voltage level for utilization. Grid interconnected photovoltaic system is accomplished through inverter. As grid requires AC power supply inverter between DC-DC converter and grid is proposed for conversion from DC to AC power supply. Power to the grid will supply only if the synchronization happens. Phase Locked Loop (PLL) as a control unit is placed for synchronization.

II- SYSTEM DISCRPTION

Solar module is a device for direct conversion of sunlight into electricity. As the photoelectric effect causes it absorb photons of light and release electrons, they are captured in the form of electric current that is electricity. A photovoltaic module consists of a number of solar cells electrically connected to each other and mounted in a support structure or frame. Modules are designed to supply electricity at a certain voltage (commonly 12 volts). The current produced is directly dependent on how much sunlight strikes the module. Photovoltaic modules and arrays produce direct current (dc) electricity. They can be connected in series and parallel electrical arrangements to produce any required voltage and current combination. This photovoltaic array module is connected to hardware of maximum power point tracker (MPPT). The power point tracker is a high-frequency dc-dc converter. MPPT is a system by adjusting the operation state of the electrical module, photovoltaic panels can output more power DC electrical system of the solar panel can be emitted efficiently. Fig. (1) below shows the block diagram of proposed system.

The MPPT controller can detect the voltage generated by the solar panel in real-time, and track the maximum voltage and current value so that the system can charge with the maximum power output. For tracking maximum power output MPPT techniques plays important role. The advance intelligent technique of tracking maximum power point based on Fuzzy logic controller (FLC) is implemented. Fuzzy logic controller is performed by Simulink. Fuzzy logic used in number of controller because it does not require an accurate model of the system to be controlled. Considering all available data, it takes best decision for given input. Using a very flexible set of if-then rule then it applied appropriate membership function and duty cycle as output is generated.

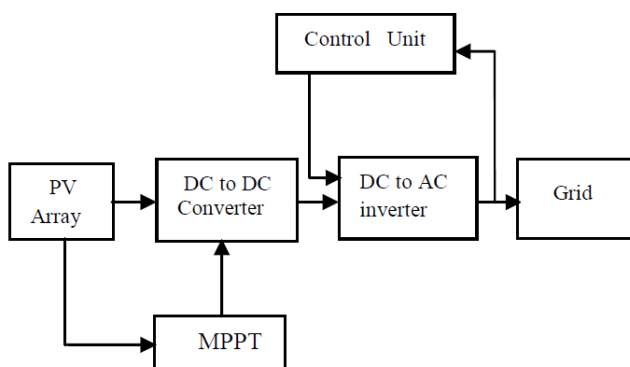

Fig. 1: Block diagram of the proposed system

DC-to-DC boost is interference between the photovoltaic (PV) array and grid. Unstable and improper voltage supplies from PV panel can lead to characteristics degradation and even malfunction. To prevent this, DC-to-DC converter is needed to stabilized the voltage. It consists the mainly input source voltage, diode, electronic switch, inductor, resistor. Major purpose of this converter is to step-up the voltage. On the load demand the boost converter can be operated. Generated duty cycle from fuzzy based MPPT controller is used to operate the switch of DC-to-DC converter. By changing the duty cycle, the load impedance is varied and matched with the point of peak power with the source and transfer the maximum power to inverter.

As grid is connected to the system it requires to convert DC power to AC. Thus, grid-tie inverter is connected between the DC-to-DC converter and utility grid. Also, inverter is for the synchronization purpose with control unit (PLL). Phase locked loop (PLL) is used for grid interfacing matches with grid parameter like voltage, current, phase, frequency with that of inverter. For synchronism to be maintained grid parameter voltage, current, phase and frequency should be same to the inverter.

III - PHOTOVOLTAIC SYSTEM

A photovoltaic module is the current source which is the combination of number of series and parallel connection of solar cells to obtain required electrical energy. By photovoltaic effect solar cell will produce dc voltage when it is expose to sunlight. Generation of current depends upon the characteristics of solar cell material, irradiation and temperature. The equivalent circuit shown in Fig. (2) the current source I_{ph} is represented by the cell photo current. R_{sh} and R_s are intrinsic shunt and series resistances of the cell respectively. Usually, the value of R_{sh} is large and R_s is very small which may be neglected.

The mathematical equation for circuit become,

$$I_T = M \cdot I_L - M \cdot I_0 \left[\exp \left(\frac{q V_T}{nkT} \right) - 1 \right]$$

Where, N is the number of cells in series, M is the number of cells in parallel, I_T is the total current from the circuit, V_T is the total voltage from the circuit, I_0 is the saturation current from a signal solar cell, I_L is the short-circuit current from a signal solar cell, n is the ideality factor of a single solar cell, q, k and T are constants.

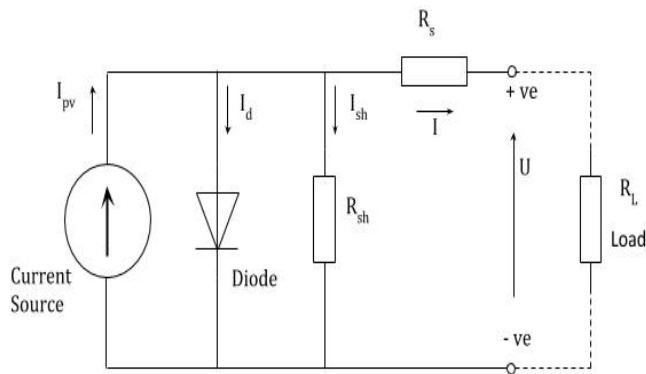

Fig. 2: Equivalent circuit of PV cell

The voltage-current characteristic equation of solar cell is provided as

Module photo current I_{ph} ,

$$I_{ph} = [I_{sc} + Ki(T-298)] \times I_r/1000$$

Here, I_{ph} : photo current (A); I_{sc} : short circuit current (A); Ki : short circuit current of cell; T : operating temperature (K); I_r : solar irradiation(W/m²).

Module reverse saturation current I_{rs} ,

$$I_{rs} = I_{sc} / [\exp(qV_{oc}/N_s K n_T) - 1]$$

Here, q : electron charge= 1.6×10^{-19} C, V_{oc} : open circuit voltage(V); N_s : number of cells connected in series; n : the ideality factor of the diode; k : Boltzmann's constant= 1.3805×10^{-23} J/K.

The fill factor is calculated from the given equation,

$$FF = \frac{P_{MAX}}{V_{OC} \times I_{SC}}$$

The ideality factor is derived from the slope, the basic cell equation in the dark is,

$$I = I_0 \left(\exp\left(\frac{qV}{nkT}\right) - 1 \right)$$

The ideal solar cell is,

$$I = I_L - I_0 \left[\exp\left(\frac{qV}{nkT}\right) - 1 \right]$$

IV- MAXIMUM POWER POINT TRACKING (MPPT)

A solar charge controller is also known as solar regulator, is essentially connected between the solar panel and load. Maximum Power Point Tracker (MPPT) is a type of solar

charge controller. MPPT are more advanced than PWM controller and enable solar panel to operate at its Maximum Power Point, or to be more precise, the optimum voltage for the maximum power output. Using this clever technology, MPPT solar charge controller can be up to 30% more efficient depending upon the load voltage and operating voltage of the solar panel. The functioning principle of MPPT solar charge controller is to track voltage and current from the solar module to determine when the maximum power occurs in order to extract the maximum power. The MPPT continuously tracks and adjusts the PV voltage to generate the most power, no matter what time of day or weather condition.

Typical cells V-I characteristics are shown in Fig. 3(a). The power delivered by a photovoltaic source depends on the operating point. The maximum efficiency is obtained when the load characteristic intersects the V-I characteristic of the source in the point corresponding to the maximum V-I plane as a function of the solar irradiation and cells temperature. The persistence of the maximum efficiency condition is related, depending on the atmospheric condition, to the tracking of the Maximum Power Point (MPP) by modifying the operating condition of the system Maximum power point tracking (MPPT).

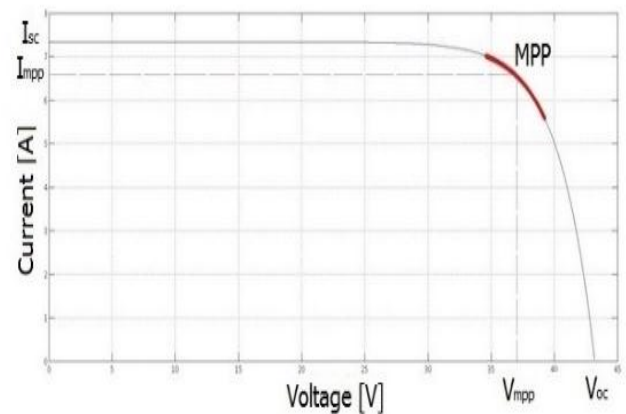

Fig. 3(a): V-I characteristic of PV cell

From above Fig. 3(a) V-I characteristic of PV cell, I_{sc} is the short circuit current and it is measured by short circuiting the terminals. V_{oc} is the open circuit voltage, and it is measured when no load is connected. MPP is maximum power point, I_{mpp} is maximum current, V_{mpp} is maximum voltage, and it occurs at the knee of the characteristics curve which indicates the operating condition where voltage and current results in Maximum Power Point (MPP).

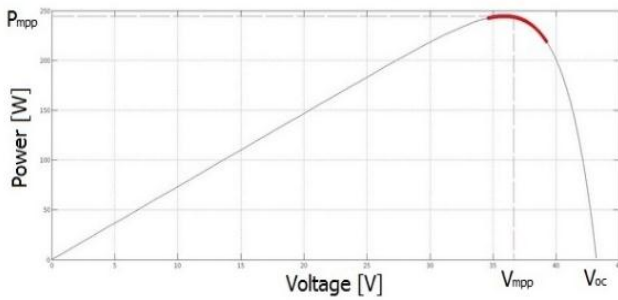

Fig. 3(b): P-V characteristics of PV cell

From above Fig. 3(b) P-V characteristics of PV cell, which is another visualization of V-I curve is a relation between power and voltage. Since the power is nothing but the voltage times of current ($P=V \times I$), the power at both the short circuit and open circuit condition is equal to zero since either voltage or current equals zero at each of these points. Where the voltage is maximum and power is zero, and as we increase the load of the circuit, the power starts increasing and the voltage falls until it reaches the value at maximum power point (MPP). If load increases further, the voltage keeps falling. However, the power will decrease as well until it reaches the value of zero at short circuit condition.

V- FUZZY LOGIC CONTROL BASED MPPT

In the real world many times we come across the situation where we can't determine the condition of state whether it is true or false. When we face inaccuracies and uncertainties of any situation the fuzzy logic provides very valuable flexibility and reasoning. In the Boolean system truth value 1.0 is represented by absolute truth value and false value 0.0 is represented by absolute false value. But in fuzzy there is no absolute truth value and absolute false value. In fuzzy logic, there is an intermediate value to present which is partially true and partially false. Fig. 4(a) shows the concept of Fuzzy Logic controller (FLC).

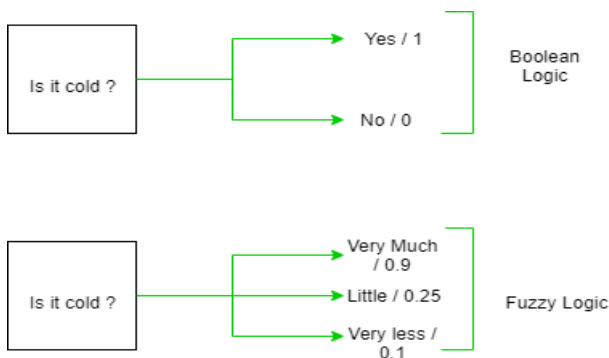

Fig. 4(a): Concept of Fuzzy Logic Controller (FLC)

Architecture of Fuzzy logic:

Fuzzy logic algorithm helps to solve a problem after considering all available data. Then it takes the best decision for given input. Fuzzy logic is used in several controllers because it does not require an accurate model of the system to be controlled. Fuzzy logic works by executing rules that correlate the controller inputs with the desired outputs. No matter what the system, there are three basic steps that are characteristic to all fuzzy logic controller. Fig. 4(b) shows the architecture of fuzzy logic. These steps include the fuzzification of the controller inputs, the execution of the rules of the controllers, the defuzzification of the output to a crisp value to be implemented by the controller.

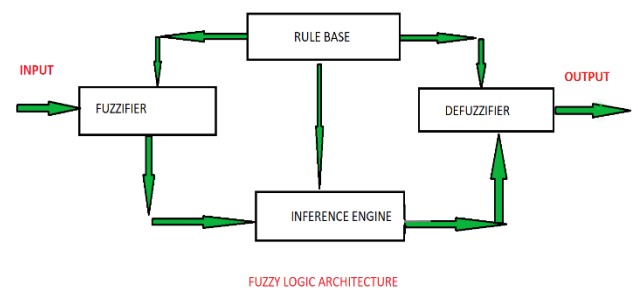

Fig. 4(b): Fuzzy logic architecture

Fuzzy logic architecture explained below:

Rule base: It contains the set of rules and the if-then conditions provided by the experts to govern the decision-making system, on the basis of linguistic information. Recent developments in fuzzy theory offer several effective methods for the design and tuning of fuzzy controllers. Most of these developments reduce the number of fuzzy rules.

Fuzzification: It is used to convert inputs i.e., crisp numbers into fuzzy sets. Crisp inputs are basically the exact inputs measured by sensors and passed into the control system for processing, such as temperature, pressure, rpm's etc.

Inference engine: It determines the matching degree of the current fuzzy input with respect to each rule and decides which rules are to be fired according to the input field. Next, the fired rules are combined to form the control actions.

Defuzzification: It is used to convert the fuzzy sets obtained by the inference engine into a crisp value. There are several defuzzification methods available and the best-suited one is used with a specific expert system to reduce the error.

Membership function of fuzzy logic:

Developing a fuzzy logic control algorithm to determine the flowchart correction term needed to achieve the desired glucose concentration $\Delta F(t)$. Defining three membership function: dissolved oxygen content (S-small; M-medium; B-big), the value of ethanol concentration (S-small; M-medium; B-big), $\Delta F(t)$ (NB-negative big; NS-negative small; ZE-zero; PS-positive small; PM-positive medium; PB-positive big). Fig. 4(c) presents graphical representation of membership function.

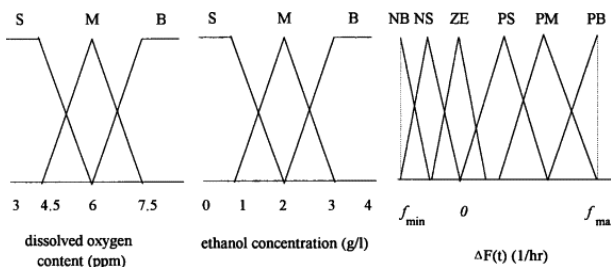

Fig. 4(c): Graphical representation of membership function

dissolved oxygen content				
	$\Delta F(t)$	S	M	B
ethanol	S	ZE	PS	PB
concentration	M	NS	ZE	PM
	B	NB	NS	PS

Fig. 4(d): Fuzzy logic production rule

Fuzzy representation for the control variable, by putting fuzzy rule in place. Fig. 4(d) represents production rule for determining $\Delta F(t)$ as a function of ethanol concentration and dissolved oxygen content. For example, if ethanol concentration is M-medium and dissolved oxygen content is S-small then $\Delta F(t)$ is N-negative small.

VI- DC-DC BOOST CONVERTER

DC-DC converters are used to efficiently produce a regulated voltage from a source that may be well controlled to a load or may not be constant. DC-DC converter is high-frequency power conversion circuits that use high-frequency switching to smooth out switching noise into regulated DC voltage. Closed

feedback loop maintains constant voltage output when changing input voltage. Unstable and improper voltage supplies can lead to characteristics degradation and even malfunction. To prevent this, a DC-DC converter is needed to convert and stabilize the voltage. For maximum voltage use of DC-DC Boost Converter is used which will step-up the voltage. The circuit diagram for DC-DC Boost Converter is shown in Fig. 5(a). Basically, it contains important elements like inductor (L), capacitor (C), diode (D), MOSFET switch. Circuit will operate on the duty cycle or signal provided to MOSFET switch.

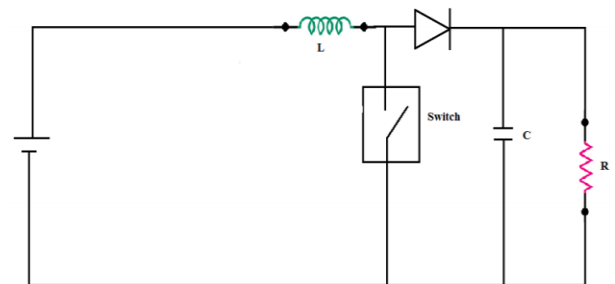

Fig. 5(a): Circuit diagram of DC-DC converter

Fig. 5(b) shows the ON state of switching component. The circuit action during the initial high period of the frequency i.e., duty cycle applied to the MOSFET gate at start up. During this time MOSFET conducts, placing a short circuit from the right-hand side of L to the negative input supply of terminal. Therefore, a current flow between the positive and negative supply terminals through L, which stores energy in its magnetic field. There is virtually no current flowing in the remainder of the circuit as the combination of D, C and the load represent a much higher impedance than the path directly through the heavily conducting MOSFET.

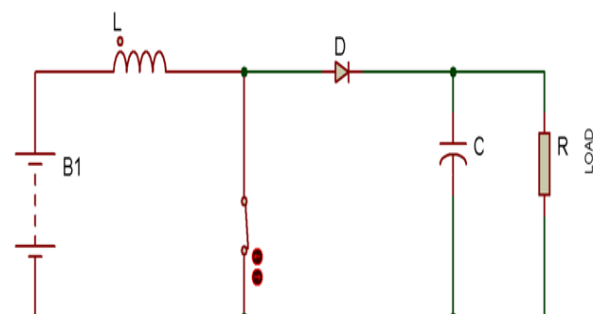

Fig. 5(b): Circuit diagram showing ON state of switching component in DC-DC converter

Fig. 5(c) shows the Off state of switching component. The low period of frequency i.e., duty cycle passed to

MOSFET. As the MOSFET is rapidly turned off the sudden drop in current causes L to produce a back e.m.f. in the opposite polarity to the voltage across L during the high period, to keep current flowing. This results in two voltages, the supply voltage and the back e.m.f. across L in series with each other.

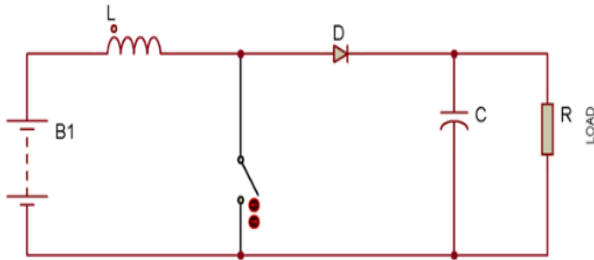

Fig. 5(c): Circuit diagram showing OFF state of switching component in DC-DC converter

The circuit action during MOSFET on periods after the initial start-up. Each time the MOSFET conducts, the cathode of D is more positive than its anode, due to the charge on C. D is therefore turned off so the output of the circuit is isolated from the input. However, the load continues to be supplied with higher voltage from the charge on C. Although the charge C drains away through the load during this period, C is recharged each time the MOSFET switches off, so maintaining an almost steady output voltage across the load.

VII- SYNCHRONIZATION WITH GRID

Phase Locked Loop (PLL) is a control system that produces an output signal in phase/reference with that of the input signal. PLL when used in grid interfacing matches the grid parameters like voltage, current, frequency with that of the inverter. Only when the voltage, current and that of the frequency and phase of the three sources are maintained the same, will there be synchronism maintained. The phase locked loop maintains the voltage constant throughout the system. The reference value of voltage is compared with inverter voltage and the error is computed. Similarly, the current value is determined. The PLL helps to maintain the inverter and the grid in synchronism and during any faulty condition it brings it back to synchronism.

VIII- RESULTS

Simulink results of Fuzzy logic controller for maximum power point tracking:

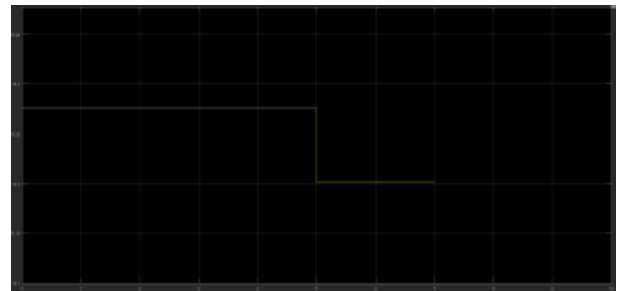

Fig. 6(a): Input current

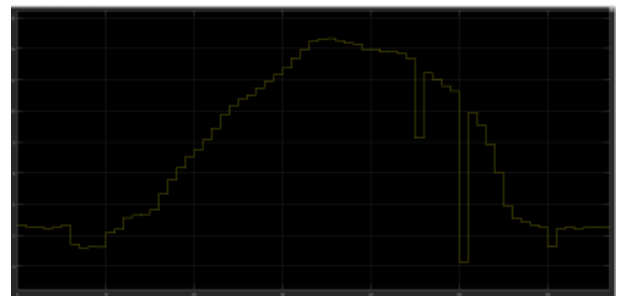

Fig. 6(b): Output current

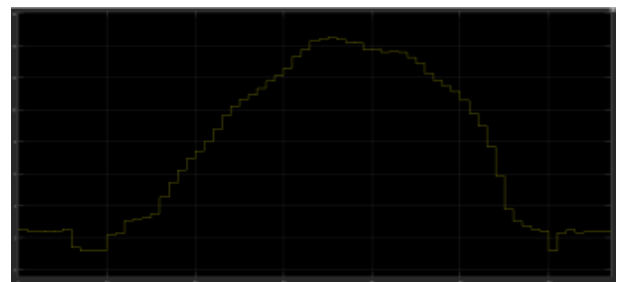

Fig. 6(c): Output power

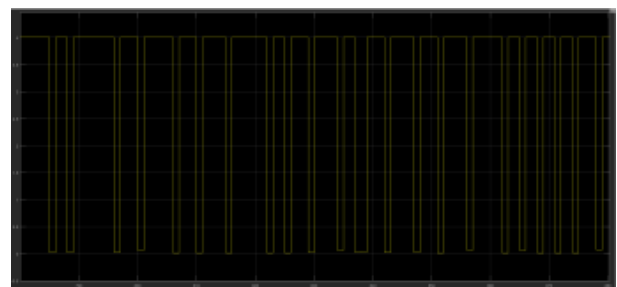

Fig. 6(d): Output PWM

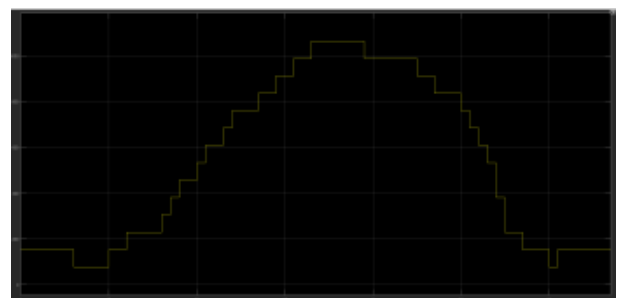

Fig. 6(e): Voltage and Current

IX- CONCLUSION

A grid connected photovoltaic (PV) system based on fuzzy logic MPPT controller is successfully implemented. Study of modelling photovoltaic system is done. For extraction of maximum power from PV array maximum power point tracker and their techniques are observed. Fuzzy logic based MPPT controller is introduced by Simulink. Considering if-then rule and membership function of fuzzy logic controller it generates duty cycle. The DC-DC converter is used for step-up voltage and also for stabilize the variable voltage from PV array. As grid requires AC power grid-tie inverter is used to interface the PV system and grid. The grid-tie inverter is placed for the conversion of power to AC power. The synchronization is control by matching the voltage, current, frequency and phase of grid to inverter.

REFERENCES

- [1] T. Bogaraj1, J. Kanagaraj2, E. Shalini3 “Fuzzy Logic Based MPPT for Solar PV Applications” in “International Journal of Innovative Research in Electrical, Electronics, Instrumentation and Control Engineering” vol.2, issue 6, June 2014 copyright to IJIREICE.
- [2] Chao Zhang, Dean Zhao, “MPPT with Asymmetric Fuzzy control for Photovoltaic System”, IEEE Africon, 2009.
- [3] Subudhi, B., and Pradhan, R. (2013). “A comparative study of maximum power point tracking techniques for photovoltaic system”. IEEE Trans. Sustain. Energy4, 89-98.
- [4] Roman, E, Alonso, A. R., Pedro, E. S, I, and Damian, G. (2006). “Intelligent PV Module for Grid Connected PV Systems”. IEEE Trans. IND. Electron.53, 1066-1073.
- [5] Christopher A. Otieno, George N. Nyakoe, Cyrus W. Wekesa, “A Neutral Fuzzy Based Maximum Power Point Tracker for A Photovoltaic System”, IEEE africon, September 2009.
- [6] Hussein, Muta, T. Hoshino, and Osakada, “Maximum Photovoltaic Power Tracking Algorithm for Rapidly Changing Atmospheric Conditins”, IEEE Power Generation, Transmission and Distribution, Vol.8, pp. 1359-1361, 2007.
- [7] Sofai. Lalouni, Djamila, Rekioua, “Modelling and Simulation of Photovoltaic System using Fuzzy Logic Controller”, IEEE International Conference on Developments in Systems Engineering, 2009.
- [8] Anwasha Panigarhi, Kanhu Charan Bhuvan, “Fuzzy Logic Based Maximum Power Point Tracking Algorithm for Photovoltaic Power Generation System” in Journal of Green Engineering, 22 September 2017.
- [9] Cheikh M. S. A., Larbes C., Kebir G. F. T. and Zerguerras A., “Maximum Power Point Tracking using a Fuzzy Logic Control Scheme”, Revue des Energies Renouvelables, Vol.10, No. 32, September 2007, pp. 387-395.
- [10] W.C. So, Tse, and Lee, “Development of a Fuzzy Logic Controller for DC-DC Converters: Design, Computer Simulation, and Experimental Evaluation”, IEEE Trans. Power Electronics, Vol.11, No.1, pp.24-32, Jan.2010.
- [11] Subiyanto, A Mohamed, M A Hannna, “Maximum Power Point Tracking in Grid Connected PV System using a Novel Fuzzy Logic Controller”, IEEE Student Conference on Research and Development, November 2009.
- [12] Chokri Ben Salah, Mohamed Ouali, “Comparison of Fuzzy Logic and Neural Network in Maximum Power Point Tracer for PV System”, ScienceDirect Electric Power Systems Research, July 2010, pp.43-50.
- [13] Basil M.Hamed, Mohammed, and EL-Moghany, “Fuzzy Controller Design using Photovoltaic Maximum Power Point Tracking”, International Journal of Advanced Research in Artificial Intelligence, Vol.1, No.3, 2012.
- [14] C. Larbes, S.M.A. Cheikh, T. Obeidi, A. Zerguerras, “Genetic Algorithm Optimized Fuzzy Logic Control for The Maximum Power Point Tracking in Photovoltaic System”, ScienceDirect Renewable Energy 34, January 2009, pp.2093-2100.
- [15] Chin, Neelakantan, Yoong, and Teo, “Optimization of Fuzzy Based MPPT in PV System fir Rapidly Changing Solar Irradiance”, Transaction on Solar Energy and Planning, pp. 410-418, 2011.