

Iot Base Agriculture Monitoring System Using Arduino and Node MCU

Pritesh Narkhede¹, Varsha Patil², Rupesh Patil³, Kunal Kawale⁴

^{1,2,3,4}UG- Student, GF'S Godavari College of Engineering, Jalgaon, India,45001,

pritesh.narkhede96@gmail.com

Received on: 29 March, 2023

Revised on: 18 April, 2023

Published on: 20 April, 2023

Abstract –Farming is an vital part of Indian economy. Over 60% of Indian residents based upon farming and one third base of the income of landsascends from farming practices. Hence it plays a vital role in the growth of the country. Various issues related to farming is nonstop impeding the progress of the country. Possible solution for these problems is to opt for modernized farming that comprises of modern trends. So farming can be made smart using IOT and other machineries. Smart farming increases crop yield, reductions water expenditure and unwarranted use of fertilizers The highlighting feature of this project is that it measures the different farming parameters affecting the yield and it also uses a GPS module to get the data about the location.also send all the data to cloud where it can be further analyzed. Thirdly this project also contains an android mobile app provided that an easy access of data to the farmer. And this project smart irrigation system that optimizes water procedure

Keywords: IoT, Smart Agriculture, Humidity, Temperature, Soil Moisture, Arduino.

I.INTRODUCTION

IntroductionInternet of Things (IoT) is the interconnectedness or network of physical devices that is interrelated computer science devices, digital and

mechanical machines, people or animals, objects that can sense, accumulate and transfer data over web without any human contribution. Everything is provided with unique identifier. [11] It is an innovative examination and mechanized frameworks which uses detection, organizing, enormous data and man-made perception innovation to convey total framework for an organization. Mostly IoT is about covering the power of internet beyond smart phones and computers. IoT has changed today's world. Smart cities, smart car, smart homes everything



Around us can be curved into a smart device with the help of IoT. Applications of agriculture, business sectors, healthcare, transport and logistics in agriculture, business sectors, healthcare, transport and logistics.

1) Low power embedded system- High performance and less battery consumption are the inverse factors that play an vital role in design of electronic system.

2) Cloud computing- Data collected from devices is stockpiled on reliable packing servers so here cloud computing comes into action.

3) Accessibility of Large Data- As IoT is extremely reliant on sensors that are real time. So the usage of automatic devices is spread throughout each field that is going to activate a massive flux of data.

4) Network connection- For communication, internet connectivity is necessary where each physical object is assigned by an IP address is build between the devices with the help of these addresses

II. LITERATURE REVIEW

Summary of literature Internet Of Things (IoT) is a shared network of objects or things which can interrelate with each other provided the internet connection. IoT plays an important role in farming industry which can feed 9.6 billion people on the Earth by 2050. Smart Farming helps to decrease wastage, effective usage of fertilizer and thereby increase the crop yield. In this work, a system is developed to monitor crop-field using sensors (soil moisture, temperature, humidity, Light) [1] In this paper, authors S. Sivacharan, K. Balkrishnan, K. Navin propose an embedded soil analyser with measures the pH value of the soil and based on this value gives measure of various soil nutrients. This model supports in estimate of the soil arrangement based on the accessibility of nutrients. Various techniques monitors various soil parameters and this paper points soil fertility. The main aim of this model is to exchange the conservative method of soil testing by automated soil testing. [2] This paper presents an IoT based smart stick that allows live monitoring of the different farming parameters. This is stick helps farmer acquire live data of temperature, soil moisture. The farming IoT stick gives the idea of plug and measures in which farmers can suddenly enact smart monitoring system by position the stick in the field and obtaining live data feeds on different smart gadgets like smart tablets, phones etc. [3]

In this paper, the author An and Nayyar, Er. Vikram Puri propositions model where the flow and way of water is

supervised and precise. This is done with the help of DHT11 and soil moisture sensor. This method also proposes a way to select the direction of water and this information is also sent to the phone and Gmail account of the farmer. This model also enables the farmer to switch on and off the motor with a single click. [4] In this paper, author Apurva C. Pusatkar, Vijay S. Gulhane focus on using WSN that is Wireless Sensor Network. Use of WSN helps in real time monitoring of the agricultural field. In adding to the conventional parameters like humidity, temperature and soil moisture, this paper focuses on water level, flood, wind direction, wind speed, weather etc. [10] The average efficiency in India is less than the world average and this paper presents a way to attain 'evergreen revolution' in agriculture. Fertilizers play a vital role in good yield but imbalanced use of P, K, N causes decrease in crop production [5]

III. PROBLEM IDENTIFICATION

The future paper aims to supply water when farm is dry without human presence and avoiding water wastage in irrigation process. And monitor the soil parameters like temperature, humidity and soil moisture level. It will also be possible to control various operations of the field remotely from anywhere, anytime by mobile as well as web application. This gives indications to the mobile phone whether to send water (that is when farm is dry) to the field or not.

IV. PROPOSED SOLUTION

The smart agriculture model main aim to avoid water wastage in the irrigation process. It is low cost and efficient system is shown below.

It contains NodeMCU, Arduino Nano, sensors like soil moisture and DHT11, Solenoid valves, relays.

- NodeMCU
- Arduino Nano
- Relay Module
- Temperature and humidity sensor
- Moisture Sensor
- Solenoid valve
- Operation

V. DESIGN

This Agriculture Monitoring System will be IoT Based Using Arduino & Node MCU technology for improving

the performance. The basic structure blocks of an IoT System are Sensors, Processors and applications. So the block drawing lower is the future model of our project which shows the interconnectedness of these blocks. The sensors are interfaced with Arduino Uno, data from the sensor is shown on the mobile app of the user. Mobile app delivers an access to the nonstop data from sensors and accordingly helps farmer to take action to fulfil the necessities of the soil. 5 volt regulator is used to energize arduino system including the sensors. ESP 8266 module which will provide wifi functionality to system. Arduino uno is the most important part of the entire system which is used to run the entire system. It works as the brain of the setup. Small solar cell is used as a light sensor. Relay is used to controller the water pump. And LED is also attached to see it's status. Soil moisture sensor is used to measure the number of Using IOT water available in the soil. LCD is used print humidity, moisture, motor status and light intensity. DHT 11 sensor is used to detect weather connection. Water pump is used to supply water. [7]

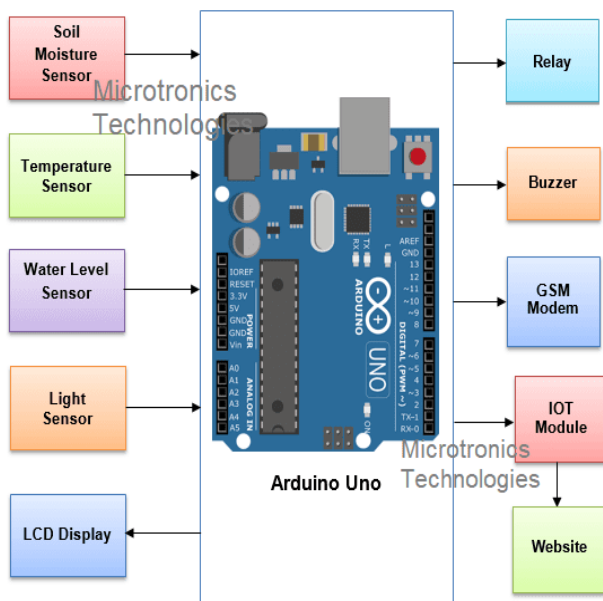

VI. METHODOLOGY

The purpose of the project is to allow the smart farming which means to decrease the guy power & problems in harvesting or any agricultural farms. And the data is right gone to the essential place of essential using the internet of things (IoT). The project uses a Arduino and Node MCU along with the Wi-Fi module with the capability of linking to the network.

The whole Arduino, Node MCU, PIR Sensor. Soil moisture sensor, Flame Sensor. Temperature and humidity sensor (DHT 11). Soil condition detector measures condition content of the soil. An infrared detector is a device that emits to sense some aspects of the surroundings. AN IR detector will live the warmth of AN object similarly as detects the motion. Flame detector is used to find the fire in the field. Fire is an unpredicted event that causes a huge loss for farmers. Agricultural fields in India are highly on alert during summer. The purpose system uses a group of sensors to detect the fire in the field including Flame sensor and Arduino and alert the user using the buzzer. When a fire is detected the automatic system triggers only if no action is taken by the user.

VII. EXPERIMENTAL RESULT

The main goal of this project is to implement the modern technology in essential fields like farming. Using IoT technology in farming, this system makes farming monitoring easy. The benefits as declared like water saving and labor saving are essential the extreme in current farming state of affairs. Subsequently, using the sensor network in fields of farming makes clever irrigation. The information from IoT is sent to the client using cloud. Consequently, any changes inside the crop may be identified effortlessly and early analysis is achieved as such. The developed hardware kit of the proposed model is shown in Figure 14.

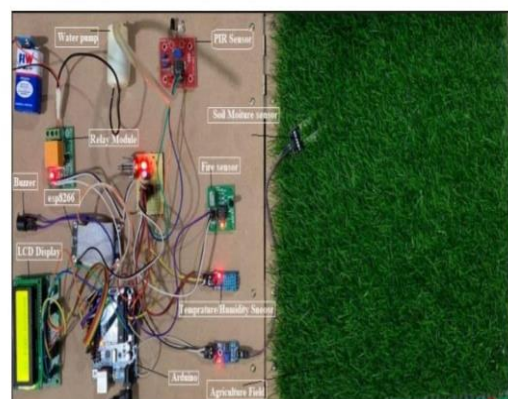

The measured and monitored parameters like temperature, humidity and moisture in soil and Flame sensor and data sending to IoT are shown in figures Figure 15 to Figure 20 respectively.

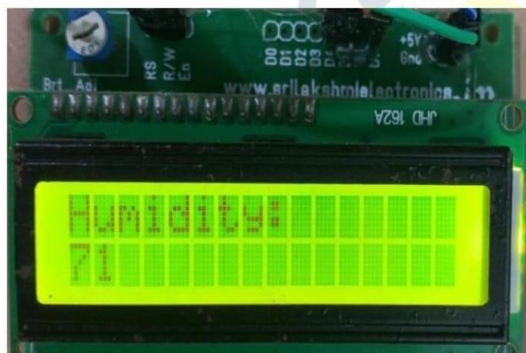

VIII. ADVANTAGES AND DISADVANTAGES APPLICATION

Advantages:

- 1) It is a robust and easy to use system.
- 2) There is no need for extra training of that person who is using it.
- 3) The schematic of Arduino is open source, for the future improvement of the project board can be extended to add more hardware
- 4) It is of low cost.
- 5) Improved livestock farming

Disadvantages:

- 1) High speed internet connection Required
- 2) When the new users need to connect, first download application software and then configuration must be done.

Applications:

- 1) Precision Farming
- 2) Green Farming
- 3) Industrial Farming
- 4) Monitoring crops
- 5) Providing data to farmers for rational farm organization plans to save both time and money.

IX. CONCLUSION

The future model travels the use of IoT (Internet of things) in the farming division. This model goals at growing the crop yield by helping in predicting better crop arrangement for a precise soil. Thing speak helps in real time sample of the soil and hence the data acquired can be further used for analyzing the crop. We have also taken many analyses of the soil moisture, temperature and humidity of the atmosphere for various days at different times of the day. Data on the cloud also helps the agriculturalists in improving the yield, assessing the manures, sickness in the fields. This system is cost effective and feasible. It similarly focuses on improving the use of water incomes which combats issues like water lack and ensures sustainability. This model focuses on the utilization of IoT in farming and the solutions proposed in this paper will improve farming methods, increase productivity and lead to effective use of limited incomes.

REFERENCES

- [1] Rajalakshmi.P, Mrs.S.Devi Mahalakshmi "IoT Based Crop-Field Monitoring And Irrigation Automation" 10th International conference on Intelligent systems and control (ISCO), 7-8 Jan 2016 published in IEEE Xplore Nov 2016.
- [2] S.Sivachandran, K.Balakrishnan, K.Navin, "Real Time Embedded Based Soil Analyser", International Research Journal of Engineering and Technology (IRJET). Volume: 3 Issue 3 | March 2014
- [3] AnandNayyar, Er. Vikaspuri, "IoT Based Smart Sensors Agriculture Stick for Live Temperature and Moisture Monitoring using Arduino, Cloud Computing & Solar Technology" May 2015.
- [4] Chandan Kumar Sahu, Pramitee Behera, "A Low Cost Smart Irrigation Control System", IEEE sponsored 2nd

International Conference on Electronics and Communication System (ICECS2015).

- [5] Prathibha S R1, AnupamaHongal 2, Jyothi M P3" IOT BASED MONITORING SYSTEMIN SMART AGRICULTURE" 2017 International Conference on Recent Advances inElectronics and Communication Technology
- [6] K. A. Patil and N. R. Kale, "A model for smart agriculture using IoT," 2016 InternationalConference on Global Trends in Signal Processing, Information Computing andCommunication (ICGTSPICC), Jalgaon, 2016, pp. 543-545.
- [7] Apurva C. Pusatkar, Vijay S. Gulhane, "Implementation of Wireless Sensor Network forReal Time Monitoring of Agriculture", *International Research Journal of Engineering andTechnology (IRJET)*. Volume: 03 issue: 05 / May-2016
- [8] Mrs.T.Vineela, J. Naga Harini, Ch. Kiranma, G.Harshitha, B. AdiLaksh, "IoT BasedAgriculture Monitoring and Smart Irrigation System Using Raspberry Pi", *InternationalResearch Journal of Engineering and Technology (IRJET)*. Volume: 5 Issue: 1 / Jan 2018
- [9] MD Safayet Ahmad, AkhlakUz Zaman, "IoT-Based Smart Agriculture Monitoring System with Double-Tier Data Storage Facility", Department of Computer Science and Engineering, Metropolitan University, Sylhet, Bangladesh, *Proceedings of International Joint Conference on Computational Intelligence, Algorithms for Intelligent Systems*
- [10] Lutful Karim, AlaganAnpalagan, Nidal Nasser, "Sensor-based M2M Agriculture Monitoring Systems for Developing Countries: State and Challenges",*Network Protocols and Algorithms ISSN 1943-3581* 2013, Vol. 5, No. 3
- [11] Chetan Dwarkani M, Ganesh Ram, "Smart Farming System Using Sensors for Agricultural Task Automation",