

A Review on Solar Air Heater

Omkar S. Arora¹, Vinod M. Wankar²

¹Student, M. Tech, Heat Power, Department of Mechanical Engineering, GHRCE, Nagpur, India

²Assistant Professor, Department of Mechanical Engineering, GHRCE, Nagpur, India

Abstract – Solar air heater is the highly used heating device for industrial application and space heating this system is used to check the different types of ribs design on the absorber plate. The review for the solar air heater with the different ribs shows the result for the different rate of heat transfer through the absorber plate. This study shows the different shape of ribs on the absorber plate and their numerical analysis is done. In this paper the study is done for different design of ribs to suggest the best suitable design for the study of solar air heater.

Key Words: solar air heater, ribs design, absorber plate, forced convection.

1. INTRODUCTION

In this era of modernization there is lack of energy sources due to the increased utilization thus solar energy is the only source which is freely available for us to use. One can use it in many different ways such as to generate the electricity, or for space heating and many other application. As this is the energy source which can be utilize as much as one can the many devices which can the run by the help of solar energy are in high demand due to the cheapness in the use of the product it is not costly to the user[1]. The ribs cause flow partition and reattachment, which rupture the flow pattern of the air and increase local wall turbulence. The inferior flows caused by disposed ribs can additional boost fluid combination in-between close to wall area and the center area[3].

A different study on solar air heater devices shows that the arrangements of the various design of ribs on absorber plate gives the variety of heat transferring rate of S.A.H, thus by comparing the various shapes and their heat transferring capacity the study on the various shapes of the ribs has been done[2]. Different surface roughness is use to separate the layer of flow and to obtain turbulence in air flow inside solar air heater, this can happen due to various geometries of the ribs used in the device which is being incorporated. This

different geometry of ribs is being tested to improve the heat transfer rate of the device which is useful for heating and drying purpose [2][3]. While performing the test for heat transfer the friction factor for air flow is also being considered in study of solar air heater device. The different shape of ribs gives the idea for the different capacity of the heat transfer and the varied friction factor thus after the analysis this devices is used for the desired purpose which fulfill the desired result obtained by the heating system [5].

The most efficient method to increase heat carrying capacity of solar air heater is to mount the different shapes of ribs on absorber plate to make the study with different geometries thus solar air heater is equipped with the varied ribs, thus shows the increase heat carrying capacity of the system [6][7]. Further it has been studied that in several heat exchanger and gas turbine the testing section has the roughen part for studying the heat transfer, the most important factor which is to be undertaken while the study is that one part of heat exchanger is heated with heater and the other parts are heated through solar radiation.

2 METHODOLOGIES AND DESIGN

2.1 Solar flat plate collector

Flat plate collector used for solar air heater is designed carefully and with keeping the solar intensity of the area in consideration proper selection of material for cover, absorber plate, the insulation and mounting frame of the solar air heater is very important aspect of the design. The absorber plate is examined with the thermal conductivity of the plate and the ribs which are placed on it ease of manufacturing and corrosion resistance body of the solar air heater. This type of collector is used because of its simple design and low costing of the setup as the total cost of project is effected the economical factor is undertaken[1][3]. The solar collector is most essential part of the solar air heater to collect the maximum amount of solar radiation the collector is mounted at certain angle according to the solar intensity and the direction of the rays falling on the flat plate collector. The ribs design is tested for the maximum heat transfer rate from the

absorber plate different size and shape gives the different data for interpretation [4].

2.2 absorber plate

The absorber plate is mainly made up of aluminum which is coated with black color so that the maximum solar radiation is absorbed and the heat transfer rate through the solar air heater is calculated and the numerical analysis is done on the different shapes of the ribs so that the best design is suggested for maximum heat transfer through the solar air heater [2]. This absorber plate is first black painted for trapping the more heat to get the better result the thickness of the absorber plate is decided through the number of ribs being used for calculation purpose. The ribs are mounted on the aluminum absorber plate and than by placing the solar air heater under the influence of air the heat transfer capacity of the solar air heater is being measured. This is the main motive of performing the experiment on the solar system to get the desired result for heating application.

shows that the heat transfer through the rectangular ribs will be more thus this shape of ribs are selected for the study of heat transfer through the solar air heater and the circular shaped ribs are also used for the comparison of the heat transfer rate.

4 SCHEMATIC DIAGRAM

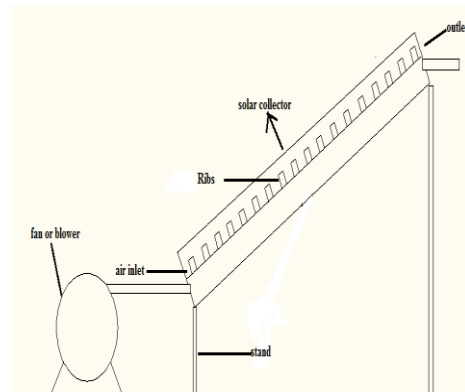

This is the purpose setup of solar air heater having the flat plate collector installed and the ribs with the absorber plate for forced convection the fan is provided at the inlet of the test section of the solar air heater .This is used to test the heat transfer effect during the forced convection as the fan is used at the inlet of the test section.

5 COST CONSIDERATIONS

As the solar system is considered as the most cost effective system this solar air heater is one of the effective system which give us the most desirable result of heat transfer through the different shape of ribs here it is circular and the rectangular ribs is used. The cost incurred in the manufacturing of the system is low as compare to the conventional solar air heater system. Material used is mild steel for the ribs, aluminum absorber plate the glass for insulation and the metal is used for the base frame. Thus this is the low cost solar air heater which gives us the idea about the heat transfer capacity of the different shape of the ribs.

6 CONCLUSIONS

From the review of various scholars the study of the solar air heater shows that the heat transfer capacity changes as the shape and size of the ribs changes thus the ribs of the solar air heater plays the vital role in calculating the heat transfer coefficient this paper conclude the review on the air heater system that how it can be developed and used for calculating the various numerical parameter such as Reynolds number and others.

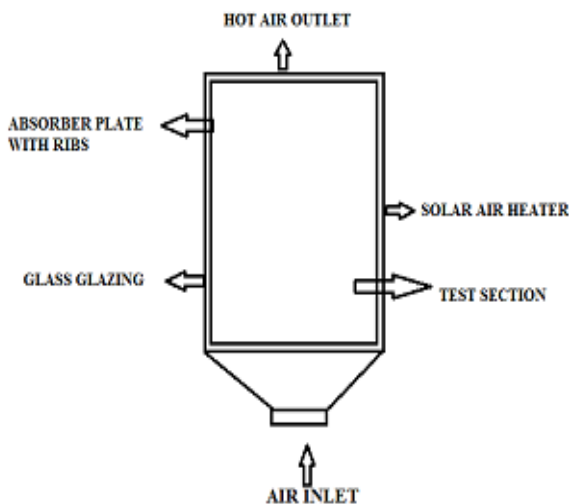

3 RIBS SHAPE, SIZE AND ARRANGEMENT

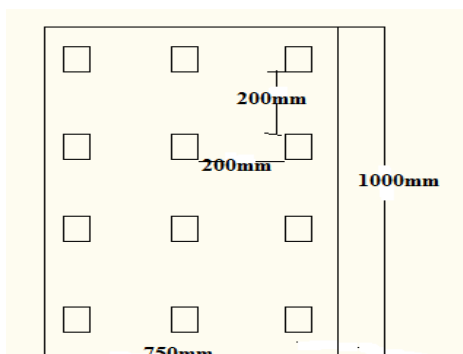

The most important part for the study of the solar air heater is the rib design and their arrangement .This is the basic design of the ribs which is being mounted on the absorber plate after the calculation being done on the solar air heater the study

REFERENCE

- [1] D. Jin, M. Zhang, P. Wang, and S. Xu, "Numerical investigation of heat transfer and fluid flow in a solar air heater duct with multi V-shaped ribs on the absorber plate," *Energy*, vol. 89, pp. 178–190, 2015.
- [2] V. B. Gawande, A. S. Dhoble, D. B. Zodpe, and S. Chamoli, "Experimental and CFD investigation of convection heat transfer in solar air heater with reverse L-shaped ribs," *Sol. Energy*, vol. 131, pp. 275–295, 2016.
- [3] M. Nem?? and J. Kasperski, "Experimental investigation of concentrated solar air-heater with internal multiple-fin array," *Renew. Energy*, vol. 97, pp. 722–730, 2016.
- [4] N. K. Pandey, V. K. Bajpai, and Varun, "Experimental investigation of heat transfer augmentation using multiple arcs with gap on absorber plate of solar air heater," *Sol. Energy*, vol. 134, pp. 314–326, 2016.
- [5] A. S. Yadav and J. L. Bhagoria, "A numerical investigation of square sectioned transverse rib roughened solar air heater," *Int. J. Therm. Sci.*, vol. 79, pp. 111–131, 2014.
- [6] N. S. Deo, S. Chander, and J. S. Saini, "Performance analysis of solar air heater duct roughened with multigap V-down ribs combined with staggered ribs," *Renew. Energy*, vol. 91, pp. 484–500, 2016.
- [7] R. Karwa and K. Chauhan, "Performance evaluation of solar air heaters having v-down discrete rib roughness on the absorber plate," *Energy*, vol. 35, no. 1, pp. 398–409, 2010.
- [8] R. Nowzari, N. Mirzaei, and L. B. Y. Aldabbagh, "Finding the best configuration for a solar air heater by design and analysis of experiment," *Energy Convers. Manag.*, vol. 100, pp. 131–137, 2015.
- [9] A. K. Patil, "Heat transfer mechanism and energy efficiency of artificially roughened solar air heaters—A review," *Renew. Sustain. Energy Rev.*, vol. 42, pp. 681–689, 2015.
- [10] A. Lanjewar, J. L. Bhagoria, and R. M. Sarviya, "Heat transfer and friction in solar air heater duct with W-shaped rib roughness on absorber plate," *Energy*, vol. 36, no. 7, pp. 4531–4541, 2011.
- [11] A. Acir and İ. Ata, "A study of heat transfer enhancement in a new solar air heater having circular type turbulators," *J. Energy Inst.*, pp. 1–11, 2015.
- [12] T. Alam and M. H. Kim, "A critical review on artificial roughness provided in rectangular solar air heater duct," *Renew. Sustain. Energy Rev.*, vol. 69, no. July 2016, pp. 387–400, 2017.
- [13] F. Chabane, N. Moumami, S. Benramache, D. Bensahal, and O. Belahssen, "Collector efficiency by single pass of solar air heaters with and without using fins," *Eng. J.*, vol. 17, no. 3, pp. 43–55, 2013.
- [14] V. S. Hans, R. S. Gill, and S. Singh, "Heat transfer and friction factor correlations for a solar air heater duct roughened artificially with broken arc ribs," *Exp. Therm. Fluid Sci.*, vol. 80, pp. 77–89, 2017.
- [15] V. S. Hans, R. S. Gill, and S. Singh, "Heat transfer and friction factor correlations for a solar air heater duct roughened artificially with broken arc ribs," *Exp. Therm. Fluid Sci.*, vol. 80, pp. 77–89, 2017.
- [16] V. S. Hans, R. P. Saini, and J. S. Saini, "Heat transfer and friction factor correlations for a solar air heater duct roughened artificially with multiple v-ribs," *Sol. Energy*, vol. 84, no. 6, pp. 898–911, 2010.
- [17] R. Karwa and G. Chitoshiya, "Performance study of solar air heater having v-down discrete ribs on absorber plate," *Energy*, vol. 55, pp. 939–955, 2013.
- [18] R. Karwa and V. Srivastava, "Thermal Performance of Solar Air Heater Having Absorber Plate with V-Down Discrete Rib Roughness for Space-Heating Applications," *J. Renew. Energy*, vol. 2013, pp. 1–13, 2013.
- [19] G. Manzolini, L. P. M. Colombo, S. Romare, and D. Fustinoni, "Tiles as solar air heater to support a heat pump for residential air conditioning," *Appl. Therm. Eng.*, vol. 102, pp. 1412–1423, 2016.
- [20] H. J. Mcqueen, M. M. Shapiro, and D. Feldman, "Selection of materials for flat plate solar collectors," *J. Mater. Energy Syst.*, vol. 2, no. 1, pp. 65–82, 1980.
- [21] A. N. Official, J. Of, H. A. Society, and R. E. P. Aper, "International Journal of," vol. 3, no. 1, pp. 72–73, 2012.
- [22] T. Rajaseenivasan, S. Srinivasan, and K. Srithar, "Comprehensive study on solar air heater with circular and V-type turbulators attached on absorber plate," *Energy*, vol. 88, pp. 863–873, 2015.
- [23] R. K. Ravi and R. P. Saini, "A review on different techniques used for performance enhancement of double pass solar air heaters," *Renew. Sustain. Energy Rev.*, vol. 56, pp. 941–952, 2016.
- [24] S. Saurav, "Heat Transfer and Thermal Efficiency of Solar Air Heater Having Artificial Roughness: A Review," *Int. J. Renew. Sustain. Energy*, vol. 2, no. 3, p. 99, 2013.
- [25] A. Saxena, Varun, and A. A. El-Sebaai, "A thermodynamic review of solar air heaters," *Renew. Sustain. Energy Rev.*, vol. 43, pp. 863–890, 2015.
- [26] G. Tanda, "Performance of solar air heater ducts with different types of ribs on the absorber plate," *Energy*, vol. 36, no. 11, pp. 6651–6660, 2011.