

# Power Factor Improvement in Modified Bridgeless Landsman Converter Fed EV Battery Charger

Prof. Umesh G. Bonde<sup>1</sup>, Prof. Sameer S.Raut<sup>2</sup>, Pragati D.Shende<sup>3</sup>

<sup>1</sup> HOD, <sup>2</sup> Assistant Prof, <sup>3</sup> Student Of Department Of Electrical Engineering MTECH (EPS) Shri Sai College Of Engineering & Technology Bhadrawati-244904  
pragatidshende1999@gmail.com

**Received on:** 25 March,2022

**Revised on:** 27 April,2022,

**Published on:** 29 April,2022

**Abstract** – This work deals with the design and implementation of a new charger for battery operated electric vehicle (BEV) with power factor improvement at the front- end. In the proposed configuration, the conventional diode converter at the source end of existing electric vehicle (EV) battery charger, is eliminated with modified Landsman power factor correction (PFC) converter. The PFC converter is cascaded to a fly back isolated converter, which yields the EV battery control to charge it, first in constant current mode then switching to constant voltage mode. The proposed PFC converter is controlled using single sensed entity to achieve the robust regulation of DC-link voltage as well as to ensure the unity power factor operation. The proposed topology offers improved power quality, low device stress, low input and output current ripple with low input current harmonics when compared to the conventional one. Moreover, to demonstrate the conformity of proposed charger to an IEC 61000-3-2 standard, a prototype is built and tested to charge a 48V EV battery of 100Ah capacity, under transients in input voltage. The performance of the charger is found satisfactory for all the cases.

**Key Words:-** Battery Operated Electric Vehicle; Battery Charger; Power Factor Improvement; Modified Landsman Converter; Power Quality.

## I- INTRODUCTION

With the strict supervision on emissions, fuel savings,

global warming issues and limited energy resources, the contribution of electric mobility is significant towards the development of sustainable and efficient alternative in the transport sector [1-2]. Regarding this, a survey based on the present scenario and future technologies for the propulsion of electric vehicle (EV), are presented in [3]. The electric mobility provides several advantages over the conventional petrol and diesel powered vehicles. However, to incorporate the transportation electrification thoroughly, deep attention of the researcher is required. Certain efficacious control strategies need to be developed to integrate them with the existing distribution system. Some of the above mentioned strategies are correlated with the power quality issues addressed by the EV chargers that associate with the charging process of battery packs [4-5].

The EVs are powered up by the rechargeable batteries to provide the necessary traction force. These batteries are typically recharged using an AC–DC converter known as an EV charger. The most general architecture of EV battery charger, comprises a boost converter at front-end and an isolated converter at the next stage [6]. The performance characteristic of this kind of charger, is exclusively decided by the performance of the DC-DC converter due to regulated output voltage and output current. Several interleaved and zero voltage switching (ZVS) PFC (Power Factor Correction) converter based

battery chargers are reported in [7-10], which reduce the inductor size and output current ripple. However, interleaving the PFC converter comes with the cost of high current stress in switches. The full-bridge topology is the prominent for PFC based EV chargers with the advantages like high power density and high efficiency but the arrangement of four switches, makes the charger control complex [11]. An LLC (Inductor–Inductor–Capacitor) resonant converter offers an attractive solution with high efficiency, low EMI (Electromagnetic Interference) noise and a high power density at wide input range [12-13]. However, due to added difficulty in design and analysis process of LLC converter, this type of topology is being substituted by unidirectional or bidirectional AC-DC converters in integrated on-board or off-board configurations [14].

input inductors  $L_{ip,n}$  as well as the benefit of low output current ripple with the conventional Landsman topology is retained in proposed topology. Two parallel converters operate in synchronization, and, in discontinuous region (DCM mode) in the respective half cycles of mains voltage to improve the power factor to unity. The DCM operation, offers the inherent benefits of low cost and simplicity in the circuit owing to the use of single sensor at the output stage [30]. A voltage follower based proportional and integral (PI) controller is used, effectively, to regulate the intermediate DC link voltage of the charger. However, the flyback converter at the second stage, designed based on [31-32], is controlled using dual loop PI controller. The battery current is regulated corresponding to 60% state of charge (SOC) to 100% SOC with the simple PI control during the conditions of constant current and constant voltage mode charging

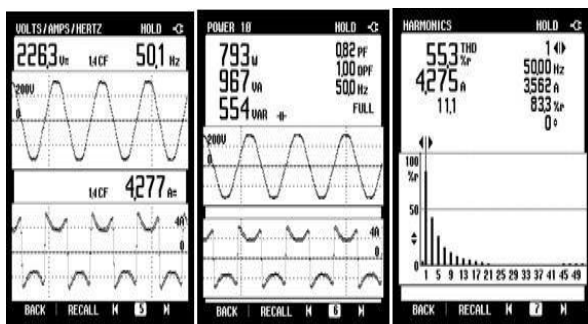
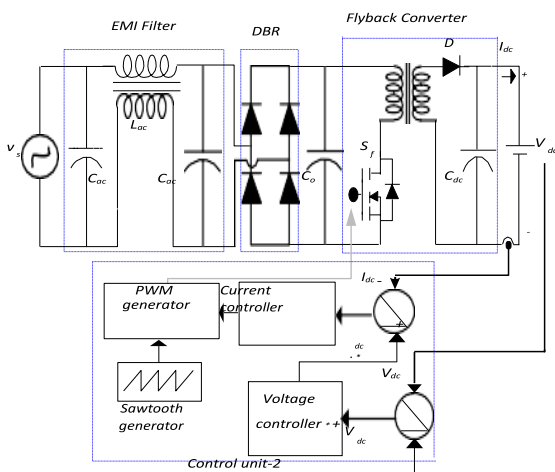

Fig. 1 Conventional E-Rickshaw Battery Charger: (a) Configuration (b) Measured input current, input power and THD in input current

The proposed Landsman converter, at the first stage, is slightly modified than that reported in [29] by rearranging the input and output side inductors. The proposed modification offers the advantage of low input current ripple, due to continuous conduction (CCM) of

## II- PRINCIPLE OF OPERATION OF MODIFIED BL CONVERTER FED CHAREGR

The proposed modified Landsman converter fed battery charger consists of two stages, a modified BL converter for improved input wave-shaping and an isolated converter for the charging of EV battery during constant current (CC) constant voltage (CV) conditions. The operation of the modified converter is selected in DCM or CCM mode based on the application requirement of low cost or low device stress, respectively. Since, the cost of the battery charger is main consideration nowadays, a DCM mode is adopted for this application. Moreover, the flyback converter also operates in discontinuous region of switching cycle to implement the control of the battery using reduced number of sensors in the circuit. Therefore, the size issues are also minimized for the proposed charger. The proposed scheme and operating principle of the two parts of the converter, are discussed here.

The intermediate DC voltage is regulated over a wide inut voltage range, through a voltage mode PI controller at the output terminal of the charger. The effectively regulated DC voltage from the BL PFC stage is given at the input of an isolated converter. This provides a synchronized charging current to the EV battery corresponding to the state of charge value

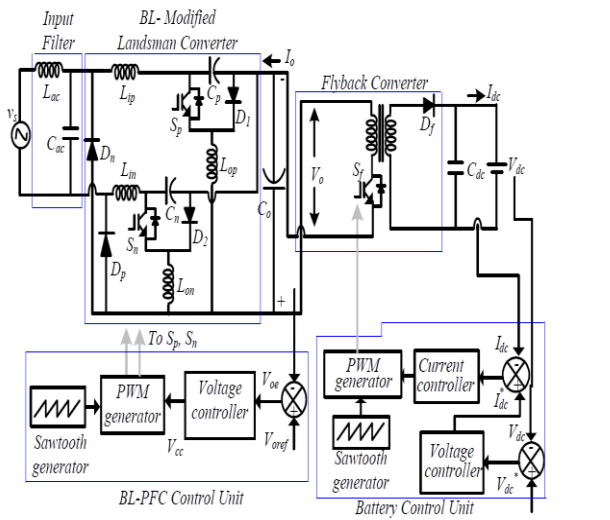

Fig. 2 Modified Bridgeless Landsman PFC Converter Fed Battery Charger for Electric Vehicle

### III- OPERATING PRINCIPLE

The operation of proposed modified BL Landsman converter and the flyback converter, is described individually in the subsequent sections.

1) Proposed Modified Bridgeless Converter Operation  
 The operation of proposed modified BL converter over complete switching cycle and during the respective half of the mains voltage, is represented in Figs. 3 (a)-(f) and waveforms in Figs. 4 (a)-(b). The operating principle during positive half cycle, is explained as follows.

Mode P-I (t0-t1): During positive half cycle of mains voltage, the converter operation begins with mode P-I. The switch SP, connected in upper line, is in ON condition and the inductor Lop starts charging through the path shown in Fig. 3 (a). During this instant, intermediate DC link capacitor, Co discharges through the isolated converter connected at the load side. However, the high frequency diode, D1 has no conducting path during this period, due to the stored charge in the inductor and hence, contains a reverse bias voltage across it.

Mode P-II (t1-t2): The high frequency diode, D1 operates in mode P-II, when the gate pulse to the switch is prevented. The inductor, Lop finds a path indicated in Fig. 3(b), to discharge through it. The DC link capacitor, Co starts charging and the flyback converter at the output, is supplied for each switching cycle.

Mode P-III (t2-t3): In mode P-III operation, the stored charge in inductor Lop is depleted completely at the end of switching cycle. The inductor current becomes discontinuous for the rest of the switching cycle. During this time, the output power is delivered by the intermediate DC link capacitor, discharging through the path indicated in Fig. 3 (c). The proposed modified BL converter follows the same switching sequence for the lower switch Sn, inductor, Lon and diode, D2 in negative half cycle of mains voltage, as shown in Figs 3 (d)-(f). Figs. 4 (a) and (b) show the switching sequence for the components operating in different modes during complete input voltage cycle and switching cycle of proposed bridgeless Landsman converter.

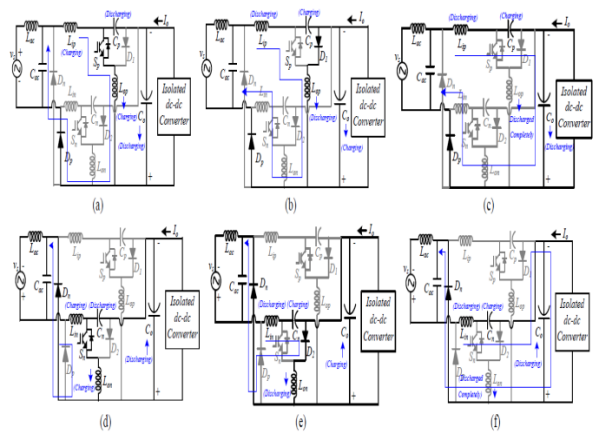

Fig. 3 Operating Principle of Modified Bridgeless Landsman converter (a)-(c) Operation for positive line cycle: Mode P-I, Mode P-II, Mode P-III (d)-(f) Operation for negative line cycle: Mode N-I, Mode N-II, Mode N-III

Moreover, to generate the required pulses for the PFC switch Sp or Sn, the intermediate voltage (Vo) is sensed through the PFC sensor. This sensed voltage is compared with a constant reference voltage of 300V (Voref). This provides the error between the two quantities, obtained as, (Voe= Voref –VO). This error voltage, Voe is given as the input to the PI controller of the BL PFC control unit. The PI controller generates a control signal (Vcc) at output that is compared to an internally generated carrier wave SfsL switched at high-frequency. This, in effect, yields the synchronized switching pulses to the PFC devices Sp and Sn, by using a PWM generator in the following pattern.

If  $S_{fsL} < V_{cc}$  and  $v_s$  is positive, then Sp is ON, else, Sn ON (or Sp remains OFF)

Where, SfsL denotes the switching pulses for the modified bridgeless Landsman converter. The appropriate PFC operation and a strictly regulated intermediate output voltage, are achieved by the variation in duty cycle over wide input voltage range.

#### IV-CONCLUSION

An improved EV charger with modified BL Landsman converter followed by a flyback converter has been proposed, analyzed, and validated in this work to charge an EV battery with inherent PF Correction. The design and control of the proposed EV charger in DCM mode have offered the advantage of reduced number of sensors at the output. Moreover, the proposed BL converter has reduced the input and output current ripples due to inductors both in input and output of the converter.

A prototype has been developed and operation of the charger has been verified by the experimental results under steady state and sudden fluctuations in input voltage. The results from the hardware validation show that the performance of proposed charger is found satisfactory for improved power quality based charging of EV battery. Moreover, the input current THD is reduced as low as 4.3% to meet the recommended IEC 61000-3-2 standard guidelines for power quality. Therefore, proposed BL converter fed charger aims at cost effective, reliable and suitable option to replace the conventional lossy and inefficient EV battery charger.

#### V- FUTURE WORK

Along with the current THD and PF regulatory requirements, a set of regulation for power efficiency and system performance might be planned and enforced in the upcoming era. The new requirements for the above regulations are expected to provide the platform for a new research area where the researchers and industries can join to address these new challenges. The future scope for the proposed work is enlisted as follows.

- The efficiency and power level could be increased to provide fast charging to the battery. Variable frequency control and modular construction approaches might aid in the optimization of the efficiency curve.
- The use of soft switching circuits for further reduction in switch voltage and current stress.

- The input and output ripple could further be reduced using interleaving of the Landsman converter cells.
- The use of wide band gap semiconductor devices (SiC and GaN based devices) leads to better converter efficiency at high power rating owing to reduced voltage drops and switching transition times.
- This work can be extended to control motor drives like BLDC and SRM motor drive for EV propulsion.
- The proposed design work can be extended to account for certain dynamic condition of battery and vehicle which gives the wide platform for future innovation to the researchers.

#### REFERENCES

- [1] Wencong Su, Habiballah Eichi, Wenten Zeng and Mo-Yuen Chow, "A survey on the electrification of transportation in a smart grid environment," *IEEE Transactions Industrial Informatics*, vol. 8, no. 1, pp. 1-10, Feb. 2012.
- [2] Ching Chuen Chan, "The state of the art of electric, hybrid, and fuel cell vehicles," *Proc. IEEE*, vol. 95, no. 4, pp. 704-718, Apr. 2007.
- [3] Kaushik Rajashekara, "Present status and future trends in electric vehicle propulsion technologies," *IEEE J. Emerg. Sel. Topics Power Electronics*, vol. 1, no. 1, pp. 3-10, Mar. 2013.
- [4] Juan C. Gomez and Medhat M. Morcos, "Impact of EV battery chargers on the power quality of distribution systems," *IEEE Transactions Power Del.*, vol. 18, no. 3, pp. 975-981, Jul. 2003.
- [5] Luca Solero, "Nonconventional on-board charger for electric vehicle propulsion batteries," *IEEE Transactions Vehicular Technology*, vol. 50, no. 1, pp. 144-149, Jan 2001.
- [6] Devendra Patil and Vivek Agarwal, "Compact onboard single-phase EV battery charger with novel low-frequency ripple compensator and optimum filter design," *IEEE Transactions Vehicular Technology*, vol. 65, no. 4, pp. 1948-1956, April 2016.
- [7] Hye-Jin Kim, Gab-Su Seo, Bo-Hyung Cho, and Hangseok Choi, "A simple average current control with on-time doubler for multiphase CCM PFC converter," *IEEE Trans. Power Electron.*, vol. 30, no. 3, pp. 1683-1693, Mar. 2015.
- [8] Adria Marcos-Pastor, Enric Vidal-Idiarte, Angel Cid-Pastor and L. Martinez-Salamero, "Interleaved digital power factor correction based on the sliding-mode approach," *IEEE Transactions Power Electronics*, vol. 31, no. 6, pp. 4641-4653, June 2016.
- [9] Muntasir Alam, Wilson Eberle, Deepak S. Gautam and Chris Botting, "A soft-switching bridgeless AC-

- DC power factor correction converter,” IEEE Transactions Power Electronics*, vol. 32, no. 10, pp. 7716-7726, Oct. 2017.
- [10] Siddharth Kulasekaran and Raja Ayyanar, “A 500-kHz, 3.3-kW power factor correction circuit with low-loss auxiliary ZVT circuit,” *IEEE Transactions Power Electronics*, vol. 33, no. 6, pp. 4783-4795, June 2018.
- [11] Jae-Hyun Kim, Chong-Eun Kim, Jae-Kuk Kim, Jae-Bum Lee, and Gun-Woo Moon, “Analysis on load-adaptive phase-shift control for high efficiency full-bridge LLC resonant converter under light-load conditions,” *IEEE Trans. Power Electron.*, vol. 31, no. 7, pp. 4942–4955, Jul. 2016.
- [12] Chuan Shi, Haoyu Wang, Serkan Dusmez and Alireza Khaligh, “A SiC-based high-efficiency isolated onboard PEV charger with ultrawide DC-link voltage range,” *IEEE Transactions Industry Applications*, vol. 53, no. 1, pp. 501-511, Jan.-Feb. 2017.
- [13] Junjun Deng, Siqi Li, Sideng Hu, Chunting C. Mi and Ruiqing Ma, “Design methodology of LLC resonant converters for electric vehicle battery chargers,” *IEEE Transactions Vehicular Technology*, vol. 63, no. 4, pp. 1581-1592, May 2014.
- [14] Chuan Shi, Yichao Tang and Alireza Khaligh, “A single-phase integrated onboard battery charger using propulsion system for plug-in electric vehicles,” *IEEE Transactions Vehicular Technology*, vol. 66, no. 12, pp. 10899-10910, Dec. 2017.
- [15] Bhim Singh, Sanjeev Singh, Ambarish Chandra and Kamal Al-Haddad, “Comprehensive study of single-phase AC-DC power factor corrected converters with high-frequency isolation,” *IEEE per Phase*, International standards IEC 61000-3-2, 2000.
- [16] Alessandro Malschitzky, Felipe Albuquerque, Eloi Agostini and Claudinor B. Nascimento, “Single-stage integrated bridgeless-boost nonresonant half-bridge converter for led driver applications,” *IEEE Transactions Industrial Electronics*, vol. 65, no. 5, pp. 3866-3878, May 2018.