

# Development of Advance Heat Exchange Evaporator Cooler

Vijay Kalbande<sup>1</sup>, Pranay Bagde<sup>2</sup>, Nikesh Bondre<sup>3</sup>, Kunal Pantawane<sup>4</sup>, Dananjay Maske<sup>5</sup>, Ritesh Choudhari<sup>6</sup>, Kshitij Dupare<sup>7</sup>, Ranjana Barapatre<sup>8</sup>

<sup>1</sup>Professor, Nagpur Institute of Technology, Nagpur, Maharashtra India  
<sup>2,3,4,5,6,7&8</sup>Research scholars, Nagpur Institute of Technology, Nagpur, Maharashtra India

**Received on:** 02 April, 2022

**Revised on:** 03 May,2022,

**Published on:** 05May ,2022

**Abstract** –Air Cooler is one of the appliances that keeping the atmosphere cold. The basic concept of water cooling is to find a medium that can handle and transport heat more efficiently than air. The authors used water as medium to transfer heat and provide less moisture air. In this project, Radiator is used to transfer heat of air by circulated water. Literature review has been carried out to collect data regarding the present design of air coolers. We have identified various types of air cooler available in the market. To overcome the problems of conventional air coolers, we fabricated advance cooler Name as Advance Heat Exchanger Cooler. The cooler provides moisture free air and more cooling effect with less water. It's a small in size and portable. This low cost air cooler can be used in houses and office..

**Keywords-** Heat Exchanger, Cooler, Radiator, Water

## I- INTRODUCTION

Maharashtra state, Nagpur district is one of the hottest city due to High temperature during summer. The scope of research paper is to find out the losses and causes by extreme high temperature. The temperature data was extracted for past years (1901-2002). According to an US world's hottest cities from India The Nagpur city is the Fifth most hottest city with maximum temperature 47.5C [1]. In India is facing a particularly difficult challenge of water crises, India about half of the population face high to extreme water scarcity conditions [2]. Cooling process is a very important

method to cool the air. Air conditioning and air cooler are widely used in the world in summer. This electrical device consumes more electricity and not beneficial for the poor people [3,4]. In summer season climate has been change and increasing the demand for comfort cooling, Air conditioning is use for the comfort cooling in summer season [5].

An air cooler works by evaporating the water. It lowers the temperature of the air using evaporative cooling. It is the addition of vapor in the air to reduce the heat. The energy needed to evaporate the water is taken from the air in the form of sensible heat, which affects of the heat exchanger coolers to battle the summer heat. They are both, cost effective and also provide a lot of comfort. So we make a cooler that is Advance heat exchanger cooler. However the rising temperatures every year means we need to use Advance heat exchanger air coolers more efficiently. An advance heat exchanger air cooler will first pull natural (warm) air from outside using a fan and then pass it through heat exchanger fins. Pump sprinkles water on top of the cooler and heat exchanger fins allows the water through fins. As the water evaporates, the temperature of the air drops and the fan blows out a current of fresh, cool air. Circulating cool air throughout your home is especially important during summer months.

## II- LITERATURE REVIEW

The exhaustive literature review carries out are as follows

Cooling process is very important to maintain the foods, fish and many items at constant temperature to avoid the effect of viruses. Cooling process employs the different methods to cool the air [4]. However the performance is dissatisfactory in the high humid regions. This project paves a way to investigate the performance of air cooler integrated with phase change material (PCM) by eliminating the problem of rise in humidity that usually encountered in the conventional air cooler[5].The cost of Evaporative coolers is low and also it consumes less power than that of AC. The main drawback of Evaporative cooler is that the air supplies by it has very large amount of Humidity [6].

Reducing energy consumption, saving water resources, recycling cool water are main directions of development. Evaporative condenser using latent heat reduces water resources waste, with energy saving advantages. This paper reviews the research status of evaporative condenser at home and abroad, and introduces the principle, classification research direction. , various influencing factors of evaporative condenser, and puts forward the future[7,8].In this paper said that evaporative coolers operate at a fraction of the energy cost of conventional residential air conditioning and can keep a home comfortably cool. Depending upon the design, an evaporative cooler can use as little as 10% of the energy consumed by refrigeration air conditioning system [9].

In his paper said evaporative coolers, also known as indirect/direct evaporative coolers hare enormous potential to provide indoor comfort and simultaneously reduce energy consumption by replacing traditional vapour compression air conditioning systems in dry to moderately dry climates [10].Ray Dabry manager of davis energy group in his paper said that two stage evaporative cooler than cool air to lower temperature than are attainable with direct (one stage) evaporative cooler and add less moisture to the indoor air. The original two stage evaporative cooler unit designed by davis energy group was developed 1999-95 with 45% match support from the energy commission's energy technologies advancement programmed [11].In his paper is very well discussed about the facts and advantage of two stage evaporative cooler as compare to single stage cooler. He said that the evaporative cooling has made a major up forward with the introduction of a two stage model specially designed for residential applications [12].

### III-PROPOSED MODEL

The advance cooler is development by using Radiator as Heat exchanger from back side of the cooler. The air cooler is design for 10x10 Square foot room. We used old conventional cooler and replaced back side by radiator. Initial cooled water flow in the radiator tube which extracts the head from incoming hot air. At the

end, water drops on the soak mad to cool the air as well as to cool the water. Maximum air flow takes place from back side of the cooler and there is no direct contact between hot air and water. Less evaporation take place without compromising cooling effect. To measure the temperature of output air, we keep on sensor to sense the temperature as shown in figure 2. The design and arrangement of the various components are as shown below 1, 2 & 3.

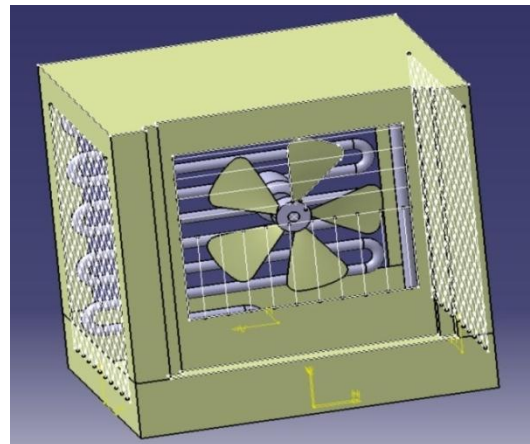

Fig 1: 3D Model of advance air cooler



Fig 2: Fabricated model of air cooler

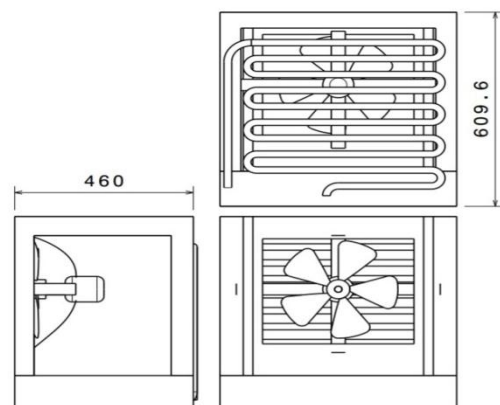

Fig 3: Dimensions of advance cooler

**IV- DATA COLLECTION & ANALYSIS**

To check the performance of modified air cooler, we have recorded the cooling effect before making modification in the cooler. After replacement of back side by radiator and few modifications, we have recorded the temperature of output air by using sensor to carry out analysis as shown in table 1.

Table 1: Collected Temp of Conventional Cooler and Advanced Cooler

Time	Weather Temp.	Conventional Cooler Temp.	Advanced Cooler Temp.
11AM	38	28.8	27
12AM	40	29	27
1 PM	41	29.1	27.5
2PM	41	29.4	27.8
3PM	41	29.2	27.7
4PM	41	28.8	27.4
5PM	40	28.5	27.1
6PM	38	29	26.9
7 PM	37	28.8	27
8PM	32	29	26.8
9PM	30	28	26.9
10 PM	29	27	26.8
11PM	29	26.9	26.8

The graph plotted between weather temperature and conventional cooler temperature, weather temperature and advance cooler temperature, conventional cooler temperature and advance cooler temperature as shown in figure 4, 5 & 6.

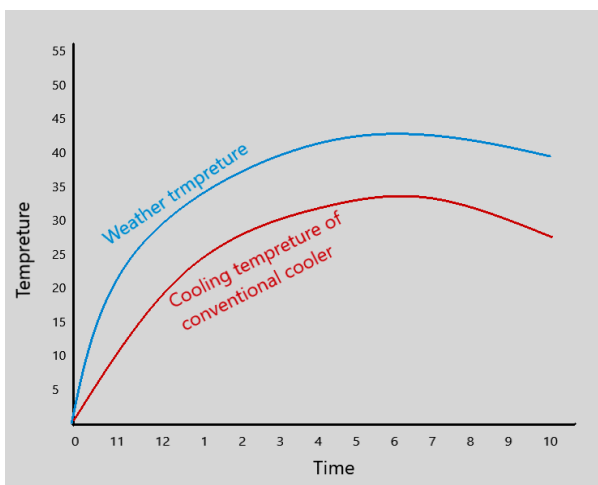

Fig 4 -Conventional cooler

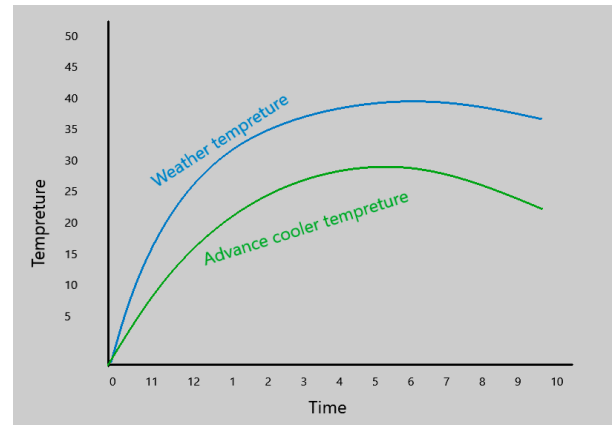

Fig 5 : Advance cooler

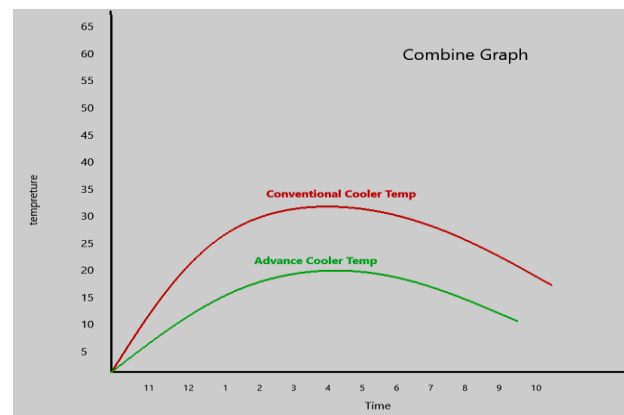

Fig 6 : Cooling temperature of conventional and advance cooler

**V-APPLICATIONS**

- It is suitable for residential applications in hot climates
- Applications that require large amounts of fresh outdoor air such as modular classrooms, gymnasiums, and commercial kitchens are also good candidates for this technology.
- That cooler is also popular and well-suited to cooling.
- The installation and operating cost of an cooler can be much lower than that of refrigerate air conditioning.
- It uses in industrial plants, commercial kitchens, laundries, greenhouses, warehouse, factories etc.

**VI-CONCLUSION**

- After the analysis it is conclude that the developed advance cooler will provide moisture free air & more cooling effect. It is summarized as fallows
- Cooling capacity is more
- Less humidified as compare to conventional cooler
- It saves water as compare to conventional cooler

- Less in cost as compared to air conditioning
- It provides comfort in hot climates.

#### REFERENCES

- [1] Ahluwalia, M.S.(2011). *Prospects and policy challenges in the twelfth plan. Economic and Political Weekly*, 46(21), pp.88–105
- [2] Amber, Brown (2011): “A Review of Water Scarcity Indices and Methodologies”, the Sustainability Consortium, April 2011.
- [3] Dr. S. Senthil, “HEAT AND MASS TRANSFER” A. R. S. publishers
- [4] C. P. Kothandaraman, “HEAT AND MASS TRANSFER DATA BOOK”, New age international publishers (seventh edition)
- [5] Arkar C. and Medved S. (2007), ‘Free Cooling of a Building using PCM Heat Storage Integrated into The Ventilation System’, *International Journal of Solar Energy*, Vol. 81, pp. 1078-1087
- [6] Sirelkhaitim K. Abbouda and Emad A. Almuhanha (2012) *Improvement of evaporative cooling Efficiency in Greenhouses by*, *Int. J Latest Trends Agr. Food Sci.* Vol-2 No 2 June 2012.
- [7] Michael T. Talbot and James H. Fletcher (2012), “Design and development of portable forced air cooler” *Automotive Research & Testing Center (ARTC)*, 2012, pp.249-255.
- [8] Sunil J. Kavle and Vivek M. Shahane (2014), “Manufacturing of 360° Rotation Air Cooler”, *International Journal of Mechanical and Production Engineering* Oct-2014, pp.0056-0072.
- [9] Roy Otterbein (2007) “Comparative Study On Thermal Performance Of Two Stage Evaporative Coolers”, *International Journal Of Elsevier*-2007,539-544.
- [10] Oliff And Berridque (1999) “Analysis Of Two Stage Evaporative Coolers”, *International Journal Of Elsevier*-1999, 233-239.
- [11] Ray Darby (2021), “Technical Note On Two Stage Evaporative Coolers”
- [12] Davis Energy Group (2000), “Performance Of Two Stage Evaporative Coolers”, 2000, pp. 111-116