

Automatic Pneumatic Bumper and Break Actuation Before Collision

Prashant Rajput¹, UmeshPatil², Gayatri Patil³, Amol koli⁴, Ganesh Koli⁵

^{1,2,3,4,5}B.E. Students, Mechanical Department, GF's Godavari Collage Of Engineering Jalgaon , 425001

¹prashantrajput2017@gmail.com

Abstract –

The technology of pneumatics plays a major role in the field of automation and modern machine shops and space robots.. The aim is to design and develop a control system based intelligent electronically controlled automotive bumper activation and automatic braking system is called AUTOMATIC PNEUMATIC BUMPER AND BREAK ACTUATION BEFORE COLLISION. This project consists of IR transmitter and Receiver circuit, Control Unit, Pneumatic bumper system and pneumatic braking system. The IR sensor senses the obstacle. There is any obstacle closer to the vehicle (with in 3-4 feet), the control signal is given to the bumper activation system and also pneumatic braking system simultaneously. The pneumatic bumper and braking system is used to product the man and vehicle. This bumper and braking activation system is only activated the vehicle speed above 30-40 km per hour.

Keywords-

IR transmitter, IR sensor, bumper, and proximity sensor.

1. INTRODUCTION

We have pleasure in introducing our project “AUTOMATIC PNEUMATIC BUMPER AND BREAK ACTUATION BEFORE COLLISION”. Which is fully equipped by IR sensors circuit and Pneumatic bumper and braking activation circuit? It is the project which has been fully equipped and designed for auto vehicles. The technology of pneumatics plays a major role in the field of automation and modern machine shops and space robots. The aim is to design and develop a control system based on intelligent electronically controlled automotive bumper activation system is called “automatic pneumatic bumper and break actuation before collision”. The project consists of IR transmitter and Receiver circuit, Control Unit, Pneumatic bumper system. The IR sensor senses the obstacle. There is any obstacle closer to the vehicle (within 1feet), the control

signal is given to the bumper and break activation system. This bumper activation system is activated when the vehicle speed above 40-50 km per hour. The speed is sensed by the proximity sensor and this signal is transfer to the control unit and pneumatic bumper activation system.

2. LITERATURE SURVEY

The aim is to design and develop a control system based on pneumatic braking system of an intelligent electronically controlled automotive braking system based on this model, control strategies such as an ‘antilock braking system ’ (ABS) and improved maneuverability via individual wheel braking system are to be developed and evaluated .

The word ‘PNEUMA’ come from Greek and means breather wind the word pneumatic is the study of air movement and its phenomena is derived from the word pneuma .

2.1 Problem Statement

In conventional vehicles there are different mechanism operated for braking system like hydraulic, pneumatic air, mechanical, etc.But all these braking mechanism received the signal of input power directly from the driver so it totally manual operated. When the driver saw the obstacle or any vehicle in front is driving vehicle, he was irritated or become mazy.

Due to this the driver fails to give the proper input to braking system and proper working is not occurs. Alsothe driver may not able to pay the full attention during night travelling so there are many chances to accident.After the accident occurs, there is no any provision to minimize the damages of vehicles. In currently used vehicle generally bumper used are rigid types.To

overcome these unwanted effects design the Automatic Pneumatic Bumper is important.

2.2 Proposed Method/System

The automatic pneumatic bumper system is used in vehicle to reduce the tendency of accident by using this system we increase the sureness of braking application also we increase response time. This system also improved pre-crash safety due to this avoid the percentage of passenger injury.

3. METHODOLOGY

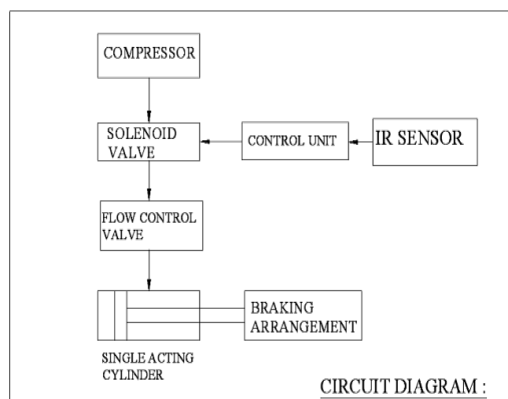

WORKING PRINCIPLE:

The compressed air from the compressor at the pressure of 5 to 7bar is passed through a pipe connected to the Solenoid valve with one input. The Solenoid Valve is actuated with Control Timing Unit. The Solenoid valve has two outputs and one input. The air entering into the input goes out through the two outputs when the timing control unit is actuated. Due to the high air pressure at the bottom of the piston, the air pressure below the piston is more than the pressure above the piston. So these moves the piston rod upwards which move up the effort are, which is pivoted by control unit. This force acting is passed on to punch/rivet which also moves downwards. The IR TRANSMITTER circuit is to transmit the Infra-Red rays. If any obstacle is there in a path, the Infra-Red rays reflected. This reflected Infra-Red rays are received by the receiver circuit is called "IR RECEIVER". The IR receiver circuit receives the reflected IR rays and giving the control signal to the control circuit. The control circuit is used to activate the solenoid valve.

COMPONENTS AND DESCRIPTION

i) SELECTION OF PNEUMATICS: Mechanization is broadly defined as the replacement of manual effort by mechanical power. Pneumatics is an attractive medium for low cost mechanization particularly for sequential or repetitive operations. may be economic and can be advantageously applied to other forms of power).The main advantages of an all-pneumatic system are usually economy and simplicity, the latter reducing maintenance to a low level. It can also have outstanding advantages in terms of safety. ii) PNEUMATIC COMPONENTS AND ITS DESCRIPTION The pneumatic bearing press consists of the following components to fulfill the requirements of complete operation of the machine. 1. Pneumatic single acting cylinder, 2.Solenoid valve 3. Flow control valve 4. IR sensor 5.unit Wheel and brake arrangement 6.PU connector, 7.reducer, 8.hose 9.collar 10.Stand 11.Single phase induction motor.

PNEUMATIC SINGLE ACTING CYLINDER: Pneumatic cylinder consist of A) PISTON B) CYLINDER



Fig. single acting cylinder

The cylinder is a Single acting cylinder one, which means that the air pressure operates forward and spring returns backward. The air from the compressor is passed through the regulator which controls the pressure to required amount by adjusting its knob. A pressure gauge is attached to the regulator for showing the line pressure. Then the compressed air is passed through the single acting 3/2 solenoid valve for supplying the air to one side of the cylinder.

SOLENOID VALVE

The directional valve is one of the important parts of a pneumatic system these are also used to operate a mechanical operation which is turn operates the valve mechanism.



Fig. solenoid valve

IR SENSOR

The most popular sensors used in remote sensing are the camera, solid state scanner, such as the CCD (charge coupled device) images, the multi-spectral scanner and in the future the passive synthetic aperture radar. Laser sensors have recently begun to be used more frequently for monitoring air pollution by laser spectrometers and for measurement of distance by laser altimeters . The sensor is used to detect the obstacle



Fig. IR SENSOR

BRAKES

Brake is a mechanical device which inhibits motion, slowing or stopping a motion object or preventing its motion. Brake is generally applied to rotating axles or wheels, but may also take other form such as the surface of a moving fluid.

APPLICATION

1. This system may be applicable in all types of light vehicles like cars, Rickshaws, Tempos.
2. This system also successfully installed in the heavy vehicles like buses, trucks, trailers, etc.

4. CONCLUSION

This project work has provided us an excellent opportunity and experience, to use our limited

knowledge. We are feeling that we have completed the work within time successfully. The PNEUMATIC BUMPER & BRAKE FOR FOUR WHEELER is working with satisfactory conditions. Thus we have prepared an“PNEUMATIC BUMPER & BRAKE FOR FOUR WHEELER” which helps to know the how to achieve low cost product.

REFERENCES

- [1] G.B.S. Narang, “Automobile Engineering”, Khanna Publishers, Delhi, 1991, pp 671.
- [2] William H. Crowse, “Automobile Engineering”.
- [3] Donald. L. Anglin, “Automobile Engineering”.
- [4] Pneumatic Control System----Stroll &Bernaud, Tata McGraw Hill Publications, 1999.
- [5] Pneumatic System---Majumdar, New Age India International (P) Ltd Publishers, 1997.