

Radio Frequency Controlled Fire Fighting Robot-A Review

Chirag Praful Mahant¹, Limchand Rajesh Koshariya², Ganesh Bhakre³, Chakradhar Bhimrao Khandekar⁴, Kartik Sanjay Munje⁵, Harsh S. Badge⁶, Akshay Kumar Waghmare⁷

Mechanical Engineering Department, Nagpur Institute of Technology, Nagpur, Maharashtra, India

Received on: 25 March,2022

Revised on: 17 April,2022,

Published on: 19 April,2022

Abstract – Fire incident is a disaster that can potentially cause the loss of life, property damage and permanent disability to the affected victim. They can also suffer from prolonged psychological and trauma. Fire fighters are primarily tasked to handle fire incidents, but they are often exposed to higher risks when extinguishing fire, especially in hazardous environments such as in nuclear power plant, petroleum refineries and gas tanks. They are also faced with other difficulties, particularly if fire occurs in narrow and restricted places, as it is necessary to explore the ruins of buildings and obstacles to extinguish the fire and save the victim. With high barriers and risks in fire extinguishment operations, technological innovations can be utilized to assist firefighting. Therefore, this paper presents the review of a firefighting robot that can extinguish fire without the need for fire fighters to be exposed to unnecessary danger. Model can be designed to be compact in size than other conventional fire-fighting robot in order to ease small location entry for deeper reach of extinguishing fire in narrow space. A camera can be also installed in this escape from that object.

Key Words:-Firefighting robot, water pump motor driver IC, Transmitter, Receiver, RF Microcontroller, Vision camera

I- INTRODUCTION

A robot is a programmable device which can be used to perform various challenging tasks. Many fire robots have been invented over the past few years but few of them can be controlled wirelessly by fireman. In some cases due to wrong readings of the sensors, the

firefighting robot fails and robot fails to perform its task of extinguishing the fire. In this paper we have designed RF based firefighting robot that can be operated wirelessly and more efficiently. The use of robots is more common today than ever before and it is no longer used by the production industries. The Fire extinguisher Robot that can detect and extinguish a fire on its own. With the invention RF based firefighting robot, people and property can be saved at a much higher rate with minimum damage caused by the fire. The Fire Fighting Robot is designed and implemented in a small floor of a house, extinguish the fire with the help of the water. Fire extinguishing is a challenging task for fireman due to physical limitations. Therefore, this RF based firefighting robot is very useful for fire fighters. This efficient Firefighting robot can be used for such high risk task of extinguishing fire. Our task as engineers is to design and build a prototype system that loaded with a water pump and this water pump is connected through water tank which was mounted on the model. Robots are designed to remove the human factor from labor intensive or dangerous work and also to act in inaccessible environment and also aims at decreasing the air pollution. It is the Robot that can move through a model structure, find a candle and then extinguish it with help of water. This paper describes the design of RF based Fire Fighting Robot. This mission is divided into smaller tasks, and each task is implemented in the most efficient manner such finds the fire in a specific room approaches the fire at a very fixed distance, extinguishes it with water. The robot designed in this paper minimize the possibility of the failure of operation of

extinguishing fire due to faulty sensor reading because operator is operating this device. The RF based fire fighting robot is capable to accurately because it was handle by human so that the fire which has more potential to spread fire can be detected and extinguished faster which reduces the possibility of fire getting spread and save property from the damage.

II- LITERATURE REVIEW

In today's era fire-fighting is a dangerous issue. Many authors are working on different techniques for fire-fighting. Several losses occur due to fire. Fire becomes the biggest disaster if it takes place near any forest area, petrol pump, gas line and any educational place. If the fire is not extinguished initially, it can harm a huge number of people as well as areas.

We are here to contribute one further step in the development of a fire-fighting robot. We have invented a simple household robot which can take place in everyone houses, every shop and malls and other common but crowded areas easily. We have used an camera which used in those areas where human was not able to see such as narrow area and also we use led lights for better vision in darker areas. There is a microcontroller which is used to control all the electronic devices working when power is supplied to them through battery. It uses water as extinguishing medium. It has handled by RF based Microcontroller which controlled by manually and this will more effective for consistency and accuracy in giving commands and sensor based are some time it goes fail.

Now day's fully automated robots are developed. Some of them with the different technologies from past years are given below:

Tushar Nandkishor Satbhai, Rahul M. Karande, Anant Vijay Patil, Prof. Manish Patil, designed and enhanced to control fire through a robotic vehicle with the advancement in the field of Robotics which they named as "firefighting Robot". They designed the fire extinguishing robotic vehicle which can be controlled wire lastly through RF communication. This vehicle is controlled through connected remote Key input. The use language input which allows a user to interact with the robot which is familiar to most of the people. In this the medium of interaction between human and computers is on the processing of speech. In this their proposed vehicle has a water jet spray which is capable capable of Sprinkling water. The sprinkle can be moved towards the

required direction. In this presented robot control system can be used for sophisticated robotics applications The controlling devices of the whole system are Microcontrollers, wireless transceiver modules, water jet spray, DC motors and buzzer are interfaced to Microcontroller. When the user fed the commands through a remote controlled device, the microcontroller interfaced to it reads the command and sends relevant data of that command wirelessly using transceiver module. When this data is received by the trans receiver module on the robot and feds it to microcontroller which acts accordingly on motors and pump. The complete system consists of two subsystems transmitter section and the receiver section. This project controls left, right, forward and backward movement of robot wirelessly within 500m range using 433 MHz RF Frequency.

V. Mangayarkarsi, designed fire fighting robot for use to control a fire and they made this model as named "Remote Controlled Fire Fighting Robot", this fire fighter robot equipped with water tank and RF remote wirelessly for extinguishing fires. For this purposes the system uses an RF remote for remote operation along with RF receiver based microcontroller Circuit for operating the Robot and water pump. This RF based remote transfer's user's commands through RF signals which are received by the receiver circuit. The receiver circuit now decodes the data commands sent. It then forwards to the microcontroller. Now the microcontroller processes these instruction and then instructions the motors to run the robot in desired direction. It also operates the solenoid valve to spray water based on user's commands. This allows the user to operate the robot and put off the fire by standing at a safe distance.

Manish Kumbhare, S Kumbhalkar, R. Malik, in their paper they cover the design and construction of a robot that is able to extinguish a fire which terms as "Fire fighting Robot", this robot is fully autonomous and implements of following concepts: Environmental sensing and awareness, proportional motor control. This robot process information from its various sensors and key hardware element via SMCL Microcontroller. In there was a ultraviolet, infrared and visible light to detect various components of its environment.

Puneet Sharma, Chandani Goel, in their project they made the robot which automatically detect the fire with the help of temperature sensors which are mounted on the robot's surface which named as "Fully Automated Fire Fighting Robot With Radio Frequency Module". This study represents the design of a fully automated fire

fighting robot and includes various modules such as temperature sensor LM35, microcontroller PIC 16F8778, 16*2 LCD and RF (Radio-Frequency) module at 433 MHz. A 12V dc motor is used to derive movements. When fire in a particular zone gets detected by the robot then it automatically reached to that zone with the help of wheels connected to the robot with the help of dc motor. There was all the modules of the study project such as RF transmitter and receiver unit, temperature sensor with LCD interface and DC motor control unit are mounted on a single ply board. The schematic of PCB (Printed Circuit Board) for each module is designed with the use of software. All the stages to design a fire fighting robot are discussed step by step in the present investigation.

Mrunalini B. Morwal, Karishma K. Malewar, Shubham R. Gadpal, Nilesh S. Panchbudhe discussed about RF based Fire Fighting Robot work is easier and faster. It controlled smoothly and comfortably by remote. The operator can easily watch the fire by the camera placed on the robot and easily extinguishes it by throwing water through DC water pump. The controls placed on RF Transmitter remote are very easy to handle and understand. When fire occurs in building or in factories or any tight places of the building where fireman can't go for extinguish fire then RF based Fire Fighting Robot can be very efficiently use for extinguishing fire with least risky human intervention. This project presents a RF based fire fighting robot using RF Transmitter and Receiver and it is designed and implemented with 8051 Microcontroller.

K. Shamilidevi, K. Akhileswar, Ch. Vinayaka, M. Karthik, Y. K. Viswanadham described about the real time fire fighting robot which moves in a constant speed, identify the fire and then extinguish it with the help of pumping mechanism. It has advantageous features such as ability to detect location of fire automatically besides having a compact body and lightweight structure. The robot can be used at a place that has a small entrance or in small spaces because it has a compact structure. The system can potentially be useful to accompany fire fighters and prevent an outbreak. The operator is able to extinguish fire using remote control from longer distance. Operators can also monitor the environmental conditions during the process of fire fighting by using the camera. From the experimental results, the robot can sense smokes and fire accurately in a short time.

Dr. P. S. Raghavendran, M. Suresh, R. Ranjith Kumar, R. Ashok Kumar, K. Mahendran, S. Swathi, L.

Kamesh, R.Sanjay presented the fire fighting rover that will help the fire fighters to save their lives without any risk. It is very helpful tool to exhaust the fire from the safe distance. It also employs the very interactive user interface and provides the precise movement and control of the rover. Expanding the model to fully automatic mechanism and also the whole arrangement can be made as easy reassembling in any other places. Also, the cost of power supply unit can be reduced by using solar power and also it becomes more users friendly.

III- PROPOSED WORK

The purpose of present study is to develop the prototype model such that it will reduce the human effort and their life risk on major fire accidents.

In this model, we are going to design and fabricate a radio frequency based prototype model of fully operational fire fighting robot, which we are planning to build in such way that it can be used as a rigid and cost effective platform which can deliver required versatile multiple utilities operations such as extinguisher cylinder implanting and some more compatibilities we are trying to focus on, which will be mounted with a camera for finding path, obstacle and will help to keep record of every work invasion done by robot. LED lights are also mounted on front and rear for better vision in dark areas and for better control and better efficiency on model we RF Microcontroller. A CAD model is developed considering parameters such that -

1. Load carrying capacity
2. Area of functionality
3. Speed variability
4. Directional movement for wheel and water jet
5. Versatile customizable top

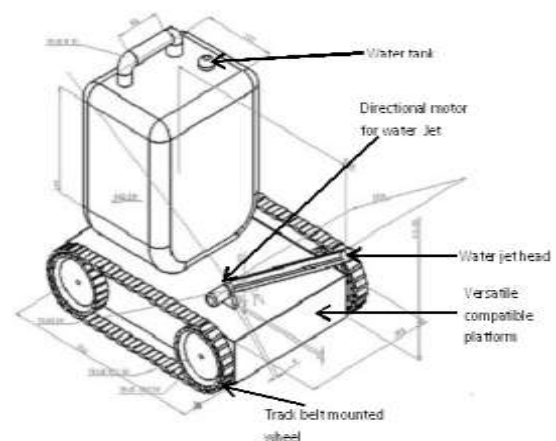

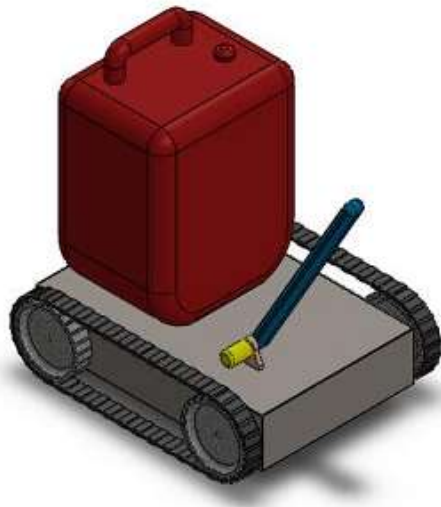

Fig. 1- Prototype 3D model

IV- CONCLUSION

From this review, lot of research has been done to ensure the safety of human in fire accidents. After this review we came to this point that the RF based Microcontroller fire-fighting Robot work is easier and faster and it controlled smoothly and comfortably by remote and RF based fire-fighting robot can be very efficiently use for extinguishing fire with least risky human invention.

REFERENCES

- [1] Tushar Nandkishor Satbhai, Rahul M. Karande, Anant Vijay Patil, Prof. Manish Patil, "Fire Fighting Robot", *International Journal on Recent and Innovation Trends in Computing and Communication* volume-4, Issue-4, April 2016
- [2] V. Mangayarkarsi, "Remote Controlled Fire Fighting Robot", *International Journal of Trend in Scientific Research and Development*, Volume-2, Issue-5, Jul-Aug:2018
- [3] Manish kumbhare, S Kumbhalkar, R. Malik, "Fire fighting Robot", an approach, *Indian streams Research Journal* volume-2, Issue-2, March-12 PP.1-4
- [4] Puneet Sharma, ChandaniGoel, "Fully Automated Fire Fighting Robot With Radio Frequency Module", *Journal of Academic and Industrial Research (JAIR)*Vol.3, Issue7, December 2014
- [5] Mrunalini B. Morwal, Karishma K. Malewar, Shubham R. Gadpal, Nilesh S. Panchbudhe , "Design & Implementation of RF based Fire Fighting Robot"(IRJETInternational Research

- Journal of Engineering and Technology* Volume: 06
Issue: 02 / Feb 2019 / ISSN: 2395-0056)
- [6] K. Shamilidevi, K. Akhileswar, Ch. Vinayaka, M. Karthik, Y. K. Viswanadham, "Fire Fighting Robot", *The International journal of analytical and experimental modal analysis* Volume XII, Issue VII, July/2020
 - [7] Dr.P.S.Raghavendran, M.Suresh, R.Ranjith Kumar, R.Ashok Kumar, K.Mahendran, S.Swathi, L.Kamesh, R.Sanjay, "An Intelligent Remote Controlled Fire Fighting Machine for Autonomous Protection of Human beings" (*International Journal of Advanced Research in Science, Engineering and Technology* Vol. 5, Issue 12, December 2018
 - [8] Mohd Aliff, MI Yusof , Nor Samsiah Sani, Azavitra Zainal, "Development of Fire Fighting Robot", (*IJACSA*) *International Journal of Advanced Computer Science and Applications*, Vol. 10, No. 1, 2019
 - [9] Scott Dearie, Kevin Fisher, Brian Rajala, Steven Wasson, "Design and Construction of a Fully Autonomous Fire Fighting Robot", 2004 IEEE.
 - [10] KashifAltaf; Aisha Akbar; Bilal Ijaz;, "Design and Construction of an Autonomous Fire Fighting Robot", 2007 IEEE. *The International journal of analytical and experimental modal analysis* Volume XII, Issue VII, July/2020