

# A Review on Grid-Tied Solar Photovoltaic System

Amol C. Wani<sup>1</sup>, Dr. P. J. Shah<sup>2</sup>, Dr. M. E. Patil<sup>3</sup>

<sup>1</sup>Ph D Research Scholar,

Department of Computer, SSBT's College of Engineering and Technology, Bambhori Jalgaon (India) 425001

<sup>2</sup>Professor

Shri Balaji Institute of Technology & Management, Betul (India) 460001

<sup>3</sup>Associate Professor

Department of Computer Engg., SSBT's College of Engineering and Technology, Bambhori Jalgaon (India 425001)

waniac7095@gmail.com

**Received on:** 29 March,2023

**Revised on:** 21 April,2023

**Published on:** 23 April,2023

**Abstract** – Solar energy is available tremendous in nature and solar photovoltaic panels generates clean energy, its efficient use thus contributes to sustainable development. As energy need continuously increasing and fossil resources decreasing, the research and development of grid-connected photovoltaic energy has become an important part of the secondary energy source in the majority of countries. This paper presents a detail review of the advances and recent technological developments of the Grid Tied Solar Photovoltaic Systems (GTSPVS). The framework of the grid-tied PV system consists of Photovoltaic (PV) array, Maximum power point tracking (MPPT) techniques, Direct Current to Direct Current (DC-DC) converters, Inverters, and control algorithms for power quality improvement which is thoroughly reviewed for better understanding of GTSPVS. Here in this paper we have also discussed the power quality issues and regulations of Grid-Connected PV System, types of DC-DC Converters, Inverter topologies and different control techniques for GTSPVS to make a significant contribution to sustainable power system for high efficiency gains of PV systems with reliable integration into the grid. This paper presents GTSPVS architecture in details along with its benefits to promote maximum and efficient use of GTSPVS. The fast advancement, innovations and developments in GTSPVS will play a significant role in efficient solar power generation along with local employment in coming days.

**Keywords-** Grid Tied Solar Photovoltaic System, Photovoltaic, Maximum Power Point Tracking, Total Harmonic Distortion

## I. INTRODUCTION

The growing population increases the energy demand and current energy need is greatly nourished through conventional nonrenewable energy sources having limited storage and resources. The researchers have found the alternative by using renewable energy which will play a significant role in energy generation to meet the future load demand. In all available renewable energy resources the solar energy catches more attention due to its clean pollution free and abundant availability proving a best alternative to conventional energy. Technological advancements in solar power system had made it feasible to use in numerous applications. Solar PV converts solar radiations into DC electrical energy and with the use of power electronics circuitry and its advancements solar energy can be generated at high efficiency and directly integrated to the grid for better utilization of PV power. In this paper, we focus our studies on the architecture and growing acceptance of GCPVS and role of DC to DC converter, MPPT algorithm and inverter topologies.

PV systems are categorized in three main types; stand-alone, hybrid and grid connected as shown in Figure 1.

Stand-alone PV systems directly supplies power to load and use battery for energy storage [1]. Hybrid PV system is a combination of solar PV with or without grid along with other energy source like wind, diesel generator etc. GTSPVS is the best option where solar PV power is connected to the utility grid through inverter with or without battery storage.

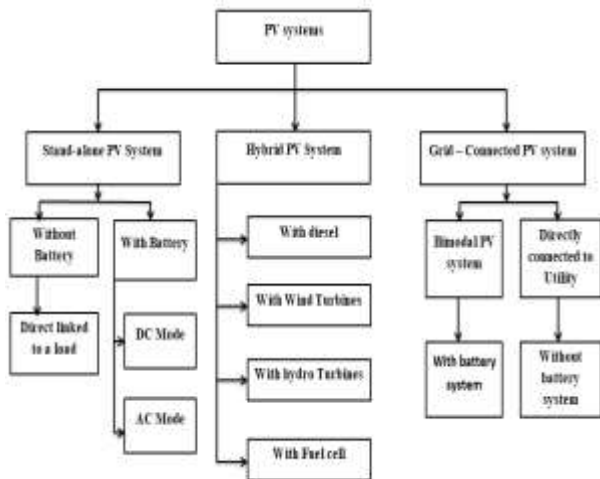

Fig. 1- Classification of photovoltaic system

## II. Power Quality Problems of GTSPVS

Solar grid integration is the process of sending solar PV power into the national utility grid. The variable and uncertain nature of solar PV systems creates various problems for reliable integration of solar systems with utility grid. The various power quality problems associated with GTSPVS includes harmonics, voltage and frequency fluctuations, unintentional islanding, Reactive power requirement etc. [2]

**Harmonics:** Harmonics are currents or voltages signal having frequencies which are integer multiples of the same fundamental frequency. Generally non-linear loads output current is in form of abrupt short pulses producing harmonics in large numbers resulting in power quality issues. As per IEEE 1547 and IEC 61727 standards the Total Harmonic Distortion (THD) should not be less than 5%. According to this standard there are limitations on DC current injection into grid with maximum limit of 1% as per IEC 61727 [3] and 0.5% according to IEEE 1547 standards [4]. The THD of the injected current is reduced by controlling the switching of the semiconductor switches in the inverter using digital control techniques.

**Voltage Fluctuation and Regulations:** The solar PV systems output power rapidly changes due to transient

clouds creating power quality problems such as voltage fluctuations in the low-voltage grid. Voltage fluctuation in low voltage grid is caused by rapid fluctuation of PV system output power due to cloud transients & becomes noteworthy with high penetration of PV systems. The measure of the voltage fluctuations depends on various factors such as total PV installed capacity, types of grid architecture and the grid location.

**Unintentional Islanding:** Unintentional islanding occurs when distributed generator like solar panel continues to generate and feed power to grid even though the larger power system is isolated from the electrical utility through the protecting devices resulting in voltage & frequency instability, power quality degradation, and equipment damage.

**Frequency Variation:** The common frequency in power system is 50 Hz or 60 Hz. The frequency variations in a power system will arise due to an imbalance between generation and load and becomes major concern in large capacity PV system resulting in load-shedding or automatically disconnecting generation from the system.

**Reactive power requirement:** The increasing use of inductive and nonlinear loads consume large amount of inductive reactive power affecting the performance of the grid. Reactive power is needed to maintain the power system's voltage stability. Inverters with reactive power control can be designed to produce both active and reactive power to keep the load power factor within the reasonable limits.

## Standards and Regulations for GTSPVS

To incorporate reliable and good quality of electric power into grid various organizations have established standards that address PV system component safety, design, installation, monitoring and regulations related to power quality issues. Some of the standards for solar PV are Institute of Electrical and Electronics Engineers (IEEE), International Electro technical Commission (IEC) and National Electrical Code (NEC) for the interconnection of solar PV energy with the utility grid. These standards provides the range and regulations of the inverter operating voltages, power factor, inverter permissible frequency changes, harmonics of the current and voltage and THD, injection of DC current into the grid system equipment safety, installation, and monitoring. According to these standards the PV system should not inject DC current greater than 0.5 % of the continuous maximum rated inverter output current into

the utility interface of rated output power and the inverter output total harmonic current distortion shall be not more than 5 % at rated inverter output [6].

### III. Grid Tied Solar Photovoltaic System

Solar PV panels consist of number of photovoltaic cells which generates electricity by converting sunlight into direct current (DC) energy. This DC is converted to Alternating Current (AC) using suitable power electronic circuit. The generalized structure of GCSPV system is shown in Figure 2. The system consists of PV panels producing DC energy which is converted to the required DC level by using DC-DC converter. This DC power obtained from the DC-DC converter is converted to require AC through an inverter or DC to AC converter which is further integrated into the single or three phase grids. Sometime the load is directly connected to the inverter output in parallel with the grid and if the solar PV system output exceeds the loads during the day, the excess electricity is fed back into the grid. The feedback control technique along with suitable control algorithm is used to digitally control the switching of the inverter switches to improve the power quality and obtaining the desired output from converter and inverter according to grid requirements. To improve the system efficiency by harvesting maximum energy MPPT technique is mostly included by using various control techniques. The solar PV panels, MPPT, DC-DC converter, inverter with control algorithm should be operated in synchronism for generating the desired AC power and its reliable integration into the grid with enhancing the overall efficiency of this complete system.

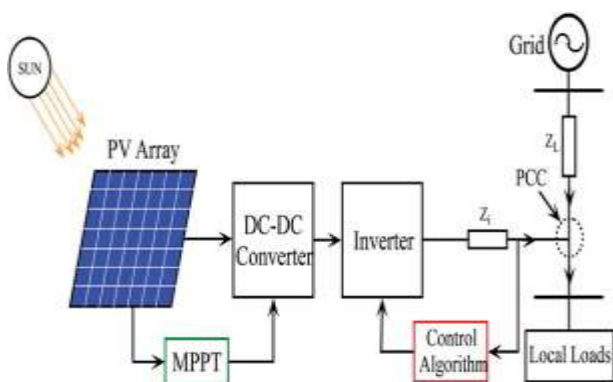

Fig. 2- Grid-Tied Solar Photovoltaic System.

The on-grid PV system offer several advantages as they are less expensive since no need of batteries, also now a days the GTSPVS is very popular in residential as well as commercial applications which may directly supply the power to the load in day time and using net metering

through which the excess electricity produced by a solar system is integrated into the utility grid and in the night time takes the electricity from the grid and thus no need of batteries for electricity storage and sometimes in some countries as per the government policies also earns the profit from this solar energy. The GTSPVS has the limitation of grid dependency such that in case of grid failure the PV system will shut down.

### DC to DC Converter

The DC to DC converter is an electronic circuitry which converts the source of DC voltage from one voltage level to another level. The output voltage of PV system needs to be matched with grid in GTSPVS. DC to DC converter step up or step down and regulates the constant PV output voltage as per the requirement under various operating conditions of PV cells. DC to DC converter maximizes the generation of solar PV by performing MPPT and detection of maximum power point (MPP) on with the help of proper MPPT control algorithm [5]. Thus it acts as a MPPT interface between the PV source and the load. In a DC to DC converter the voltage conversion is achieved by controlling the switching operation of the switches by properly controlling the duty cycle or operation period of the switches using appropriate pulse modulation technique. The four basic types of DC-DC converter used in solar PV systems are buck converter, boost converter, buck boost converter and cuk converter.

### Classification of DC-DC Converters:

The DC-DC converters are broadly classified into isolated and non-isolated converters.

**Non-Isolated Converters:** In non-isolated converter transformer is not used and there is no physical separation between input and output hence they are smaller in size, light weight and less expensive, simpler in design and have high efficiency. The drawback is that it there is no protection against high electrical voltages. They types of non-isolated converters are as follows.

**1. Buck Converter:** Buck Converter is a DC to DC converter performing the step down conversion of applied dc input where fixed dc input voltage is reduced to a lower dc output voltage also known as the step-down converter. It works on the principle of storing energy in an inductor which is proportional to the change in the electric current flowing through the device. This converter is mostly used for connecting the larger module voltages to the lower loads.

**2. Boost Converters:** Boost Converter is a DC to DC converter performing the step up conversion of applied dc input where fixed dc input voltage is boost to a higher dc output voltage also known as the step-up converter. It works on the principle that inductor resist changes in current by either increasing or decreasing the energy stored in the inductor magnetic field. This converter is mostly used in PV applications for connecting the lower module voltages to the higher loads.

**3. Buck-Boost Converters:** The buck–boost converter is an integration of basic buck and boost converter output whose output voltage magnitude is either less than or greater than the input voltage. The output voltage magnitude depends on the duty cycle of the switching element.

**4. Cuk converter:** It is buck-boost converter used to either step up or step down the DC output voltage. It is the cascaded form of buck and boost converter with an series connected capacitor.

**Isolated Converters:** In the isolated converter the input and output terminal are electrically isolated providing the safety & high isolation voltage properties. They are further categorized into two types.

**1. Fly back converters:** It is an isolated power converter similar to the buck-boost converter that uses split inductor to form a transformer which stores energy.

**2. Forward Converters:** It uses a transformer which increase or decrease the output voltage and provide isolation for the load.

**Maximum Power Point Tracking (MPPT)**

MPPT operates using an algorithm embedded in DC to DC converter to track the voltage and current of the solar PV module to determine when the maximum power occurs for extracting maximum available power from PV module under conditions of varying solar radiations, temperature and load conditions and thus increases the efficiency of the solar PV panel [7]. Every PV panel has an operating point known as MPP based on its current-voltage and voltage-power characteristics. MPPT changes the duty cycle of the DC to DC converter as per the varying conditions and matches the solar cell source impedance with the load impedance for maximum power transfer and operated the solar PV panels closer to MPP.

The classification of MPPT techniques is as shown in figure 3. The selection of the proper MPPT algorithms depends on tracking speed, solar panel voltage, efficiency, cost and complexity to track the MPP. The different MPPT techniques and characteristics of are as listed in table 1.

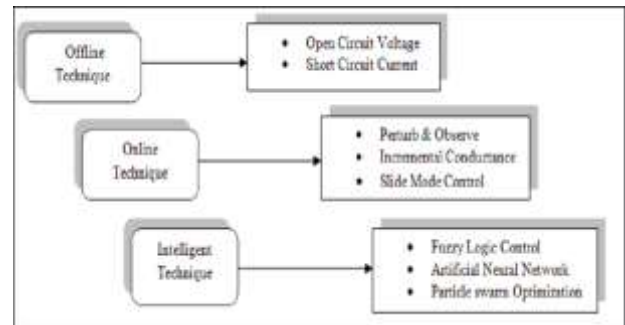

Fig. 3- Classification of MPPT Techniques.

Table 1- Major Characteristics of a MPPT Method [10]

MPPT method	Type	Complexity	Digital or analog	Convergence speed	Sensed parameters	Prior training	Efficiency
Open circuit voltage	Offline	Low	Both	Medium	Voltage	Yes	Low (~85%)
Short circuit current	Offline	Medium	Both	Medium	current	Yes	Low (~85%)
Artificial neural networks	Offline	High	Digital	Fast	Depends	Yes	High (~90%)
Fuzzy logic	Offline	High	Digital	Fast	Depends	Yes	High
P&O (Fixed perturbation size)	Online	Low	Both	Low	Voltage and current	No	Low
P&O (variable perturbation size)	Online	Medium	Digital	Fast	Voltage and current	No	High (~90%)
ESC	Online	Medium	Both	Fast	Voltage and current	No	High (~97%)
IncCond	Online	Medium	Digital	Depends	Voltage and current	No	High
Method of [26]	Hybrid	Medium	Both	Fast	Voltage, current and temperature	No	High (~98%)

**Classification of Solar PV Inverter**

In the grid-connected PV system, the DC power of the PV array should be converted into the AC power with proper voltage magnitude, frequency and phase to be connected to the utility grid. Under this condition, a DC-to-AC converter known as inverter is required which plays a very prominent role in grid-synchronization [8].

According to the power rating and solar PV architecture and grid connection the inverters can be classified into string inverters, central inverters, multi-string inverters and micro inverters. String inverters are connected with solar panels in strings where each string has its own MPPT. These are generally used for medium power applications [9]. Central inverter topologies are mostly used for large power applications having centralized inverter and common MPPT for all PV arrays. Multi-string topology is a combination of central and string inverter with each string having its DC–DC converter and tied to a single inverter. Microinverters are generally

used in small power applications where each PV modules has its individual inverter and MPPT. The detail comparison is given in table 2.

Table 1- Comparison of different PV System Topologies

Factor	Centralised	String	Multi-string	Micro
Type of Connection	PV panels are interfaced to single, centralised inverter	PV panels connected in strings comprise an inverter	Many PV strings are connected in Parallel having its specific DC-DC converter	Each PV module has an inverter integrated into it
Power Range	High, small-scale and utility-scale	medium small-scale and utility-scale	small-scale and utility-scale	low small-scale
Scalability	not at all flexible	flexibility to some extent	flexibility to some extent	very flexible
Efficiency	medium	very high	medium	high
MPPT Effective	low	medium	medium	high
Failure Chance	very low	low	medium	high
Advantages	low cost, robust and easy maintenance.	each string can be oriented in directions of maximum power	every string can now be controlled individually	each panel can be optimally tracked
Disadvantages	high losses & maintenance cost	inverter sensitivity increases	Complex system & low efficiency	high cost, lower efficiency.
Phase	3 Phase	1phase/3 Phase	1 phase/3 Phase	1 phase

**Power Electronic Inverter Topologies**

The solar PV grid inverter are made up of power electronics circuitry and based on the commutation process generally categorized into line commutated inverters and self commutated inverters as shown in Figure 4. The self commutated inverters are of two types

current source and voltage source inverter. The details of each are discussed further.

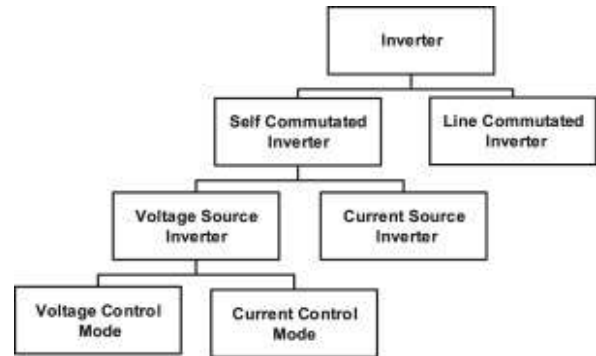

Fig. 4-Classification of Inverter

**Line Commutated Inverter:** In Line Commutated Inverter (LCI) semi-controlled semiconductor switching devices like thyristors are used which are turn on the gate control and the turn off through grid voltage or line current by changing the polarity of ac voltage.

**Self Commutated Inverter:** Self Commutated Inverter (SCI) are fully controlled converters using MOSFET and IGBT as switching devices whose turn-off and the turn-on process are controlled through gate terminal control. MOSFETs are used for high frequency applications with power ratings not more than 20 kW and IGBT are used for low frequency applications with power ratings greater than 100 kW. The SCI are preferred over LCI due to robustness to the grid providing better power factor and reduction in harmonics. The types of SCI are current source inverter and voltage source inverter.

**Current Source Inverter:** In current source inverter the input current polarity remains the same as dc current source is connected to the input to the inverter and ac current waveform with constant amplitude and variable width is obtained at the output side. Here a high value inductor is to be used in series for current stability make circuit bulky, costly and decreases efficiency.

**Voltage Source Inverter:** In voltage source inverter the input current polarity remains the same as dc current source is connected to the input to the inverter and ac current waveform with constant amplitude and variable width is obtained at the output side. Here a large capacitor is connected in parallel with the input increasing efficiency with reduction in weight and cost. Hence the voltage source inverters are mostly used in GTSPVS as compared to current source inverters. The voltage source inverters are operated in operated either in voltage control mode or in current control mode.

#### IV. Inverter Control Techniques

The control techniques for GTSPVS [10] are done in two major parts: First PV panel control using MPPT to harvest the maximum power from PV panels and Secondly through the grid-side control of PV inverters for power quality improvement and satisfying the requirements of the utility grid.

#### V. CONCLUSION

GCSPV system is one of the most promising technologies to support electricity generation using renewable source of energy and to satisfy the increased load requirement in an effective manner. The large availability of solar light and power electronics technological advancements have made this system highly efficient and cost effective. This review article presents a comprehensive review on GCSPV system, its associated problems, and their structure and inverter standards. A comparative study of different components, MPPT methods DC-DC converters along with their application is presented. In these review paper classifications of inverters and their topologies connected to grid comparative study is presented along with their pros and cons. It is expected that, in coming future improved design and updated technology will make this grid connected inverters perform with highest efficiency and reliability. This detail review will help the researches working in this area of GTSPVS.

#### REFERENCES

- [1] *Jalal Assadeg, Kamaruzzaman Sopian, Ahmad Fudholi, Performance of grid-connected solar photovoltaic power plants in the Middle East and North Africa”, International Journal of Electrical and Computer Engineering (IJECE) Vol. 9, No. 5, October 2019, pp. 3375~3383*
- [2] *S. Yasmeena, G. Tulasiram Das, “A Review of Technical Issues for Grid Connected Renewable Energy Sources”, International Journal of Energy and Power Engineering, Volume 4, Issue 5-1, September 2015, Pages: 22-32*
- [3] *P. M. Rooij, P. J. M. Heskes, “Design Qualification of inverters for grid connected operation of PV power generation” Dutch guidelines Edition 2, pp.13-21, March 2004 October 2019, pp. 3375~3383*
- [4] *IEEE Std 1547 , “IEEE Application guide for IEEE standard for interconnecting distributed resources with electric power systems” IEEE standard coordinating committee for fuel cell, photovoltaic, dispersed generation pp. 12-60, 15 April 2009.*
- [5] *Ajay Kumar, Nitin Gupta and Vikas Gupta, “A Comprehensive Review on Grid-Tied Solar Photovoltaic System”, Journal of green Engineering, Vol. 7, 213–254, 2017.*
- [6] *Anjali, Gourav Sharma, “A Review on Grid-Connected PV System”, International Journal of Trend in Scientific Research and Development, Volume 1(4), 2017*
- [7] *Mohannad Jabbar Mnati, Victor Gino Morais Araujo, “Review Different Types of MPPT Techniques for Photovoltaic Systems”, Conference Paper, June 2018.*
- [8] *Muhammad Yasir Ali Khan, Haoming Liu, Zhihao Yang and Xiaoling Yuan, “A Comprehensive Review on Grid Connected Photovoltaic Inverters, Their Modulation Techniques, and Control Strategies”, Energies 2020, 13, 4185.*
- [9] *Dharani Kolantla1, Suresh Mikkili1, Suneel Raju Pendem , Aditi Atul Desai, “Critical review on various inverter topologies for PV system architectures”, ET Renew. Power Gener., 2020, Vol. 14 Iss. 17, pp. 3418-3438*
- [10] *Ali Reza Reisi a,n , Mohammad Hassan Moradi b , Shahriar Jamasb, “Classification and comparison of maximum power point tracking techniques for photovoltaic system: A review”, Renewable and Sustainable Energy Reviews, Volume 19, March 2013, Pages 433-443*
- [11] *Rocky Chhikara, Deepak Dua, Neha Mehta, “Review Paper On The Grid Connected PV System & Related Problems”, International Journal Of Engineering Sciences & Research Technology, 2015.*